

# Royo<sup>®</sup>

MODULAR 2020

MODULAR 2020

MODULAR 2020

MODULAR 2020

MODULAR 2020

MODULAR 2020

MODULAR 2020

MODULAR 2020

MODULAR 2020



Royo®



0 Intro\_p.06

1 Collections x3

1-1 Mio\_p.08

1-2 Wave\_p.46

1-3 Vida\_p.72

2 Technical\_p.107

UN ESTILO  
DE VIDA,  
UN BAÑO.

MIL ESPACIOS,  
MILLONES  
DE  
POSIBILIDADES.

---



*EN\_One lifestyle, one bathroom.  
A thousand spaces, millions of possibilities.*

*FR\_Un style de vie, une salle de bains.  
Un millier d'espaces, des millions de possibilités.*

*IT\_Uno stile di vita, un bagno.  
Mille spazi, milioni di possibilità.*

# En Royo nos hemos planteado un reto:

## Diseñar tantos baños como estilos de vida existen.

Por eso presentamos Royo Modular, más que un producto, una filosofía de diseño. Diseños que se ajustan a cada espacio gracias a su modularidad y a la posibilidad de combinar acabados y complementos.

En definitiva un mueble versátil y único para cada forma de entender el baño.

Cada uno somos como somos. Somos nuestros gustos y nuestras manías. Somos seres únicos, singulares, que vivimos acorde a aquello que nos completa y sustenta. Cada uno de nosotros gozamos de un estilo de vida.

Podemos ser un alto ejecutivo en el sector financiero que debido a sus continuos viajes de negocio ve su hogar como su refugio personal, donde comienza el día en el baño con una ducha reparadora tras una sesión de cardio.

O quizá, cada noche nos reunamos en el baño con nuestra pareja y nuestras tres pequeñas fierecillas para cepillarnos los dientes juntos para darles ejemplo, por muy excéntrico que parezca.

Tenemos claro que existe un amplio abanico de formas de contemplar y disfrutar la vida, por eso en Royo hemos adaptado nuestros diseños democráticos para poder ofrecer un baño a cada estilo de vida.

No importa si eres una madre soltera o una pareja con hijos independizados, Royo Modular permite plantear millones de posibilidades por su modularidad y sus diferentes combinaciones de acabados y complementos, creando así un mueble de baño versátil y exclusivo para cada estilo de vida.



*EN\_At Royo we've set ourselves a challenge: to design a bathroom for every lifestyle. That's the reason we present Royo Modular: it is more than just a product, it is a design philosophy. It adapts to any space thanks to its modular design and the possibility of combining finishings and accessories. In short, a versatile and unique piece of furniture for every type of bathroom.*

*FR\_Chez Royo, nous nous sommes fixé un défi : concevoir autant de salles de bains qu'il y a de styles de vie. C'est pourquoi nous présentons Royo Modular, plus qu'un produit, une philosophie du design. Des conceptions qui s'adaptent à chaque espace grâce à leur modularité et à la possibilité de combiner les finitions et les accessoires. Bref, un meuble polyvalent et unique pour chaque façon de comprendre la salle de bains.*

*IT\_Alla Royo ci siamo prefissati un obiettivo: progettare tanti bagni quanti sono gli stili di vita. Per questo, presentiamo Royo Modular, che più di un prodotto è una filosofia di design. Design che si adattano ad ogni spazio grazie alla loro modularità e alla possibilità di combinare finiture ed accessori. In sostanza, un mobile versatile ed unico per ogni tipologia di concezione del bagno.*

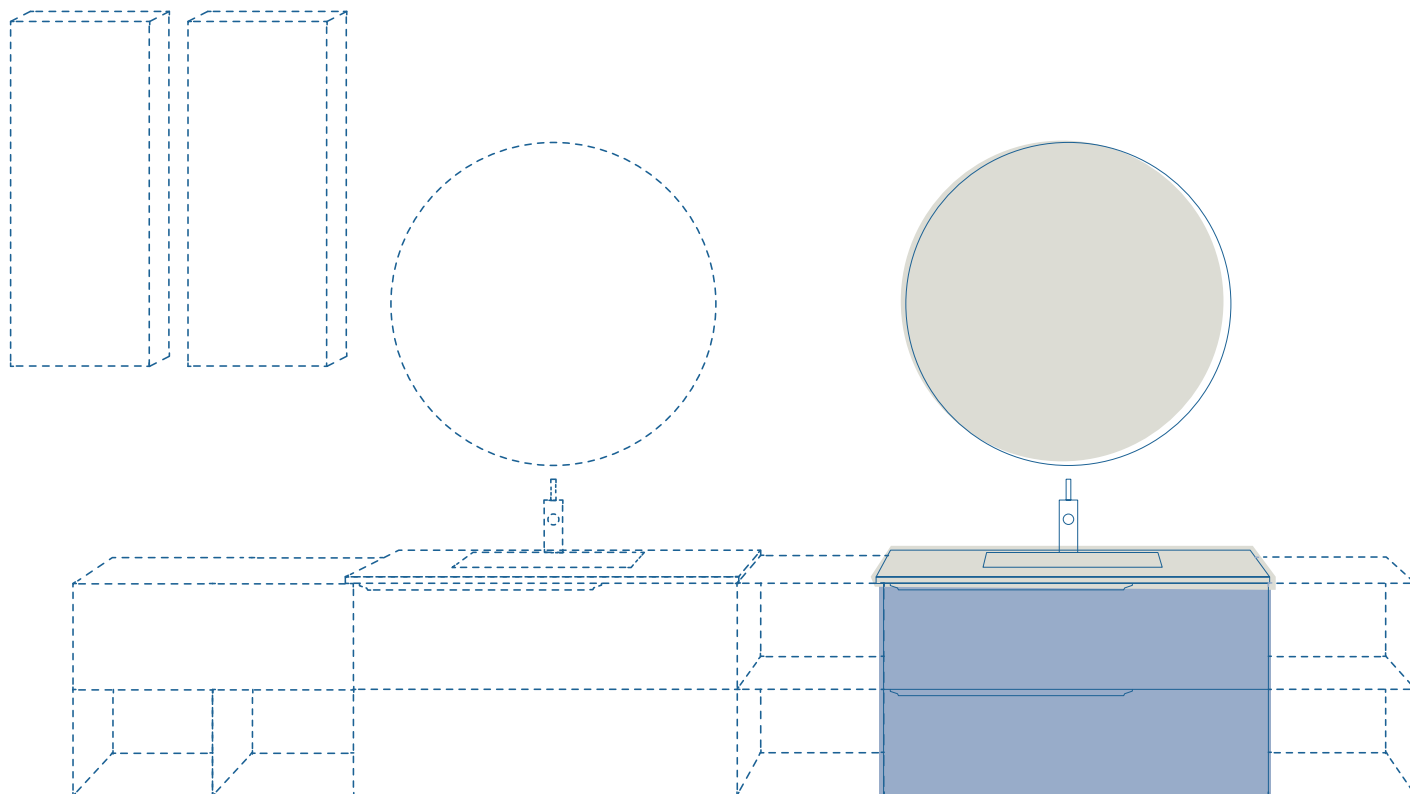

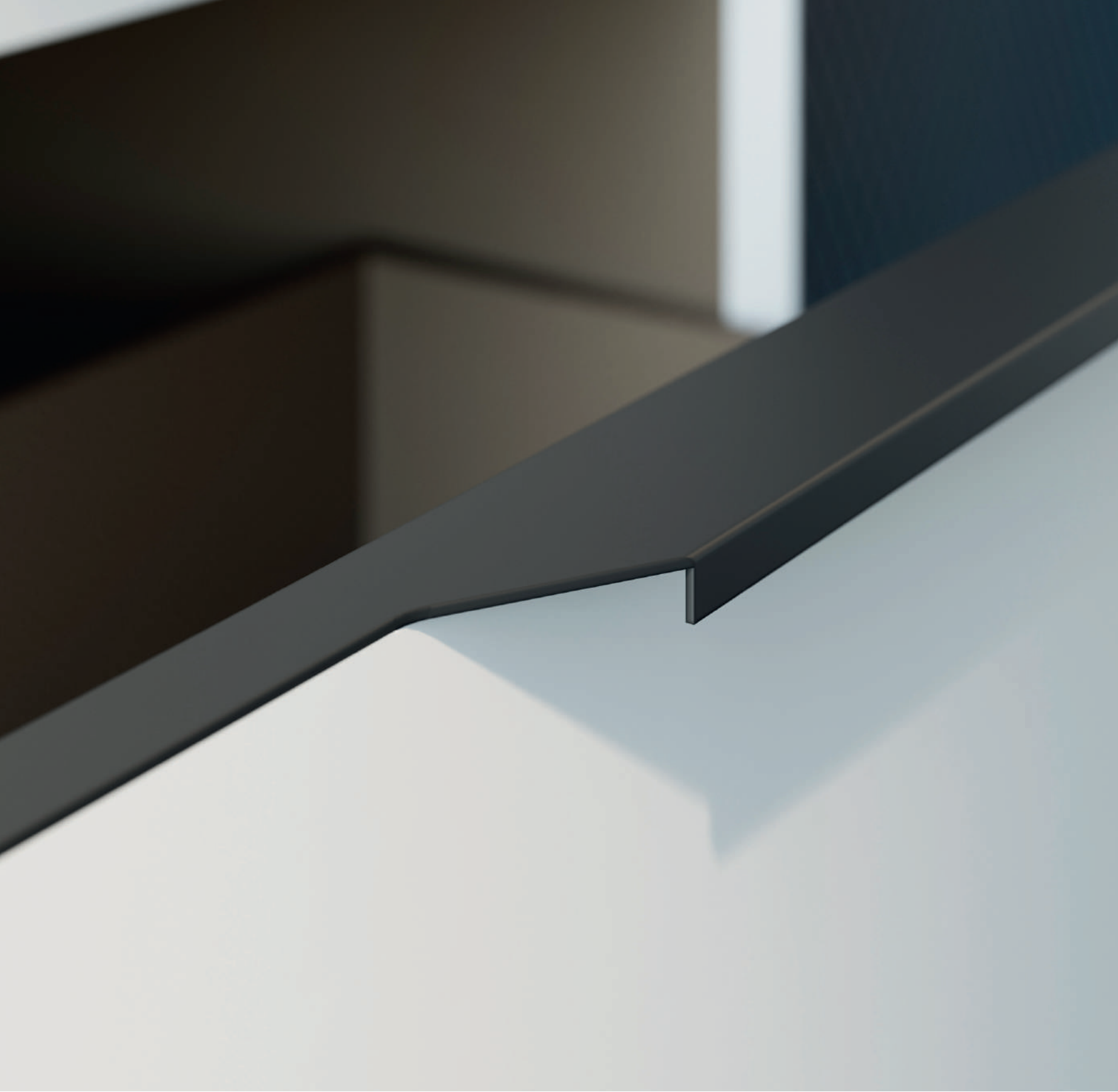

# 1-1

/Ignacio Lacroze

/Rosa y Juan

/Restaurante Root

/Turia-Hotel

/Aaron y Marc



Libertad total  
para crear un  
mueble de  
baño que se  
adapta 100%  
a tu espacio  
y gusto.

---

*ES\_Mio es la respuesta si buscas un espacio equilibrado. Un diseño elegante y contemporáneo con altas prestaciones funcionales y con una estética única. Mio destaca por sus líneas rectas y un tirador en angular, discreto, pero con personalidad.*

*EN\_Mio is the answer if you're looking for a well-balanced space. An elegant and contemporary design with excellent functions and a unique look. Mio stands out for its straight lines and angular handle, a subtle but personal touch.*

*EN\_Complete freedom to create a bathroom furniture that is 100% adapted to your space and taste.*

*FR\_Une liberté totale pour créer une salle de bains qui s'adapte à 100% à votre espace et à vos goûts.*

*IT\_La libertà totale di creare un mobile da bagno che si adatta al 100% al tuo spazio e ai tuoi gusti.*

—

*FR\_Mio fera l'affaire si vous recherchez un espace équilibré. Un design élégant et contemporain avec des performances fonctionnelles élevées et une esthétique unique. Mio se démarque par ses lignes droites et une poignée angulaire, discrète mais avec de la personnalité.*

*IT\_Mio è la risposta se stai cercando uno spazio equilibrato. Un design elegante e moderno con alte performance funzionali e con un'estetica unica. Mio si distingue per le sue linee rette e una maniglia in angolare, discreta ma con una certa personalità.*

# Ignacio Lacroze

Ignacio Lacroze (41) es soltero y trabaja como alto ejecutivo en el sector financiero. Su trabajo le obliga a viajar la mitad de los días del año, por lo que su vivienda es un refugio personal. Por eso le gusta que esta sea un reflejo de su personalidad: elegante y minimalista. Cuando llega a casa tras un viaje de negocios le gusta relajarse y ponerse al día con alguna serie. Su ritual para comenzar el día comienza en el baño: practicar deporte y una ducha reparadora.

## ¿Cómo recargas pilas para comenzar el día?

Me despierto pronto y salgo a correr. Luego una ducha y antes de salir me miro en el espejo y digo mi mantra. Parece una tontería, pero me da muchas fuerzas para arrancar con energía.

## ¿Un gadget del que no puedes prescindir?

Mi smartwatch, que me sirve tanto de agenda de trabajo como para monitorizar la actividad que hago.

## ¿Tu ciudad preferida?

Cuando viajas por negocios tienes poco tiempo para ver la ciudad, por eso prefiero alguna mediana como Valencia o Eindhoven, donde siempre tienes algo interesante cerca del hotel.

*EN\_Ignacio Lacroze (41) is single and works as a senior executive in the financial sector. His work forces him to travel for half of the year, so his home is his personal sanctuary. For this reason, he likes it to reflect his personality: elegant and minimalist. When he arrives home after a business trip, he likes to relax and catch up with a TV series. His morning ritual begins in the bathroom: practising sport and then a refreshing shower.*

*FR\_Ignacio Lacroze (41 ans) est célibataire et travaille comme cadre supérieur dans le secteur financier. Son travail l'oblige à voyager la moitié de l'année, de sorte que sa maison est un refuge personnel. C'est pourquoi il aime qu'elle reflète sa personnalité: élégante et minimaliste. Lorsqu'il rentre chez lui après un voyage d'affaires, il aime se détendre et rattraper son retard sur certaines séries. Son rituel pour attaquer la journée commence dans la salle de bains: du sport et une douche réparatrice.*

*IT\_Ignacio Lacroze (41) è single e lavora come senior executive nel settore finanziario. Il suo lavoro lo obbliga a viaggiare per metà dell'anno, per cui la sua casa è un rifugio. Per questo motivo gli piace l'idea che sia un riflesso della sua personalità: elegante e minimalista. Quando rientra a casa dopo un viaggio di affari, ama rilassarsi e guardare qualche serie tv. Il suo rituale per iniziare la giornata comincia dal bagno: praticare sport e una doccia ristoratrice.*









# IGNACIO LACROZE





ES\_Un baño para recargar pilas./ EN\_A bathroom to recharge batteries.  
FR\_Une salle de bains pour recharger les batteries./ IT\_Un bagno per ricaricare le pile.

# Rosa y Juan

Rosa (54) y Juan (57) viven en Gandía y se declaran 'pro-edad', personas encantadas y a gusto con cumplir años. Sus hijos se independizaron recientemente, momento que aprovecharon para reformar el baño y darle un nuevo aire. En sus ratos libres les encanta descubrir restaurantes nuevos de la zona y salir a la montaña.

## ¿El plan perfecto para el fin de semana?

Salir con nuestra perra Cloti a hacer una ruta de senderismo por la provincia.

## ¿Qué veis cuando os miráis en el espejo?

Nosotros no tenemos ningún miedo de mirarnos al espejo. Nos tomamos las arrugas como un trofeo, un recordatorio de la vida tan feliz que hemos compartido las últimas dos décadas y un montón de años espectaculares que están por venir.

## ¿Cómo se vive vuestra nueva independencia?

Pues es a medias porque nuestros hijos nos visitan muy a menudo, pero eso nos encanta. Tenemos una habitación para cuando vienen y en el baño hemos puesto varios camerinos con espejo, por lo que tienen un espacio reservado para sus cosas.

*EN\_Rosa (54) and Juan (57) live in Gandía and declare themselves 'pro-age', people who are happy and at ease with getting older. Their children recently became independent, a moment which they took advantage of by renovating the bathroom and giving it a breath of fresh air. In their spare time they love to find new restaurants in the area and escape to the mountains.*

*FR\_Rosa (54 ans) et Juan (57 ans) vivent à Gandía et se déclarent «pro-âge», des gens qui sont ravis et heureux de leur anniversaire. Leurs enfants sont récemment devenus indépendants et ils en ont profité pour rénover la salle de bains et lui donner un nouveau look. Pendant leur temps libre, ils aiment découvrir de nouveaux restaurants dans la région et aller à la montagne.*

*IT\_Rosa (54) e Juan (57) vivono a Gandía e si dichiarano 'pro-età', persone felici e a proprio agio con l'avanzare degli anni. I loro figli sono diventati autonomi da poco, per cui ne hanno approfittato per ristrutturare il bagno e dargli un tocco nuovo. Nel tempo libero, amano scoprire nuovi ristoranti della zona e andare in montagna.*











## ROSA Y JUAN



ES\_Espacios que te rejuvenecen./ EN\_Spaces that make you younger.  
FR\_Des espaces qui vous rajeunissent./ IT\_Spazi che ringiovaniscono.

# Restaurante Root

Las complicaciones del día no pueden ser una barrera para comer bien, es el lema de Root, un restaurante ubicado en el distrito financiero de París y el sitio ideal tanto si tienes poco tiempo, pero quieres un menú sano, como si quieres desconectar. Root cuenta con una zona de healthy fast food y un salón-cafetería para degustar productos de km 0 con más tranquilidad. La coherencia entre propuesta gastronómica e interiorismo se traslada a todos los espacios: salón, recepción y, por supuesto, el baño. Cada rincón respira la filosofía del espacio.

*“Es uno de mis sitios de referencia del barrio. Además de la comida me encanta el interiorismo, cada detalle está cuidado, desde la barra, las vistas y hasta el baño”, declara Julie, consultora para operadores turísticos.*

François, trabajador de banca, también es asiduo, cuando acaba de trabajar. *“Voy a un gimnasio cercano y luego vengo para llevarme algo de cenar a casa. Si tengo clientes o colegas siempre los traigo aquí porque el ambiente es relajado y la comida excelente”.*

*EN\_Daily hassles shouldn't be a barrier to eating well: that's the motto of Root a restaurant located in Paris' financial district, and the ideal place if you don't have much time but you want a healthy menu, or just want to get away. Root has a healthy fast food area and a lounge-café where you can enjoy local products with more tranquility. The consistency between the gastronomic offer and the interior design is transferred to all areas: lounge, reception and, of course, the bathroom. Every corner breathes the location's philosophy.*

*FR\_Les complications de la journée ne peuvent pas constituer un obstacle à une bonne alimentation. Telle est la devise de Root, un restaurant situé dans le quartier financier de Paris qui est un endroit idéal, si vous manquez de temps mais voulez un menu sain en vous déconnectant. Root dispose d'un espace healthy fast food et d'un salon-café pour la dégustation des produits de km 0 avec plus de tranquillité. La cohérence entre la proposition gastronomique et la décoration d'intérieur est transférée à tous les espaces : le salon, la réception et, bien sûr, la salle de bains. Chaque coin respire la philosophie de l'espace.*

*IT\_I problemi quotidiani non possono essere un ostacolo al mangiare bene” è il motto di Root, un ristorante situato nel distretto finanziario di Parigi. Il luogo ideale sia se si ha poco tempo ma si desidera un menu sano, sia se si vuole staccare la spina. Root dispone di un'area healthy fast food e un salone-caffetteria per degustare prodotti a km 0 in tutta tranquillità. La coesione tra la proposta gastronomica e l'interior design viene riproposta in tutti gli spazi: salone, reception e, ovviamente, in bagno. Ogni singolo angolo respira la filosofia del luogo.*









## RESTAURANTE ROOT



ES\_Espacios que te hacen sentir bien./ EN\_Spaces that make you feel good.  
FR\_Des espaces qui vous font du bien./ IT\_Spazi che ti fanno sentire bene.

# Turia-Hotel

Turia Hotel en Valencia es una muestra de una nueva generación de hoteles, desenfadados y sin complejos. Un espacio-boutique ideal si viajas por negocios, ya que cuenta con una zona de trabajo. Además está ubicado en el corazón del barrio del Carmen, lo que te permite aprovechar ratos libres para descubrir la ciudad. Las habitaciones presentan un equilibrio perfecto entre diseño y funcionalidad. Se trata de dormitorios-suite con zona de lavabo integrada en perfecta armonía con el interiorismo general.

*“Tengo un negocio online que me permite trabajar desde cualquier parte del mundo. He elegido este hotel porque es cómodo para trabajar y me encantan sus habitaciones. Lo mejor es que tiene un baño integrado muy cómodo, pero con mucha personalidad”,* nos cuenta Sharon, empresaria de un negocio online, que ha establecido su base de operaciones de forma temporal en este hotel.

*“Cuando busco hoteles siempre miro fotos antes de reservar. Para mí es imprescindible que además de cómodo sea bonito. El baño tiene que ser de diseño y funcional porque se puede tener todo. Por eso me encanta el Turia Hotel”,* afirma Carmen.

*EN\_Turia Hotel in Valencia is an example of a new generation of hotels, carefree and uninhibited. An ideal boutique place if you travel for business, because it has a work area. It's also located in the heart of Barrio el Carmen, which lets you use your free time to discover the city. The rooms present a perfect balance between design and functionality. It has bedroom suites with an integrated washing area, in perfect harmony with the general interior design.*

*FR\_L'hôtel Turia à Valencia est un échantillon d'une nouvelle génération d'hôtels, décontractés et sans complexes. Un espace boutique idéal si vous voyagez pour affaires, car il dispose d'un espace de travail. Il est également situé au cœur d'El Carmen, ce qui vous permet de profiter de votre temps libre pour découvrir la ville. Les chambres présentent un équilibre parfait entre design et fonctionnalité. Il s'agit de chambres-suites avec un espace sanitaire intégré, en parfaite harmonie avec la décoration générale de l'intérieur.*

*IT\_Il Turia Hotel a Valencia è un esempio di una nuova generazione di hotel, informali e senza complicazioni. Uno spazio-boutique ideale se si viaggia per affari, dato che dispone di un'area di lavoro. Inoltre, è situato nel cuore del barrio del Carmen, che consente di approfittare dei momenti liberi per scoprire la città. Le stanze presentano un equilibrio perfetto tra design e funzionalità. Si tratta di camere-suite con la zona del lavabo integrata in perfetta armonia con l'interior design generale.*









# /TURIA



ES\_Baños en los que nadie deja huella.  
EN\_Bathrooms where nobody leaves a trace.



FR\_Des salles de bains dans lesquelles personne ne laisse de traces.  
IT\_Bagni in cui nessun lascia il segno.

/HOTEL

# Aaron y Marc

Aaron (32) y Marc (39) tienen una pequeña galería de arte en Londres. Son urbanitas y aman el diseño. Su casa es limpia y no les gusta abusar de la decoración, pero cada una de las piezas que poseen está cuidadosamente seleccionada. Les encanta cuidarse y tienen un baño espacioso de estilo contemporáneo.

## ¿La última adquisición que habéis hecho para vuestra casa?

Han sido dos. Un super clásico del diseño, la silla Cesca de Marcel Breuer, y una pequeña escultura del artista mexicano Luis Úrculo. La hemos puesto en el baño porque creemos que es un espacio muy íntimo donde disfrutar de una manera diferente del arte.

## ¿Vuestro descubrimiento más reciente en la ciudad?

Close-up, un pequeño cine-cafetería en el barrio de Shoreditch donde ver auténticas joyas del cine independiente, imposibles de encontrar en otros sitios.

## ¿Un restaurante que no hay que perderse?

Spiritland en Kings Cross, café de día y sitio de copas de noche. Allí hacen sesiones de electrónica y charlas de artistas como Nick Hornby o Tom Dixon.

*EN\_Aaron (32) and Marc (39) have a small art gallery in London. They are city dwellers and love design. Their house is clean and they don't like to overdo decoration, but every piece they own is carefully chosen. They enjoy looking after themselves and they have a spacious contemporary bathroom.*

*FR\_Aaron (32 ans) et Marc (39 ans) tiennent une petite galerie d'art à Londres. Ce sont des citadins et ils chérissent le design. Leur maison est propre et ils n'aiment pas abuser de la décoration, mais chaque pièce qu'ils possèdent est soigneusement sélectionnée. Ils aiment prendre soin d'eux et disposent d'une salle de bains spacieuse de style contemporain.*

*IT\_Aaron (32) e Marc (39) possiedono una piccola galleria d'arte a Londra. Sono ragazzi di città, amanti del design. La loro casa è pulita e non amano esagerare con le decorazioni. Tuttavia, ciascuno dei pezzi presenti in casa sono stati scrupolosamente selezionati. Amano curarsi e hanno un ampio bagno in stile moderno.*











# AARON Y MARC



ES\_Lugares íntimos con arte./ EN\_Intimate places with art.  
FR\_Des lieux intimes avec art./ IT\_Luoghi intimi con arte.

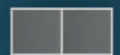
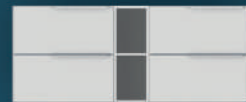
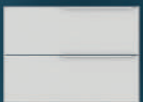
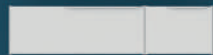
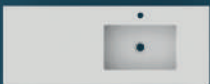
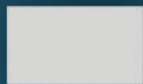
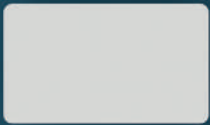
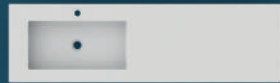
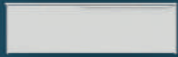
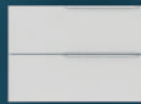
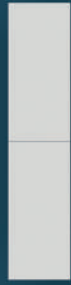
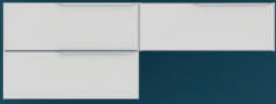

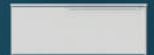
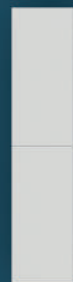
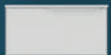
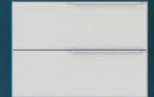
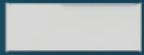
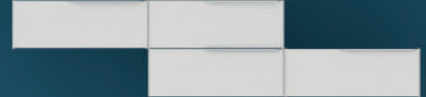
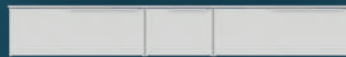
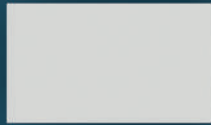
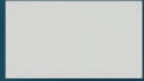



MIO 06



MIO 07



MIO 08



MIO 09



MIO 10



MIO 11



MIO 12



MIO 13

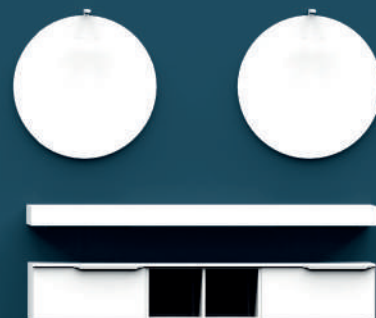

MIO 14



MIO 15



MIO 16

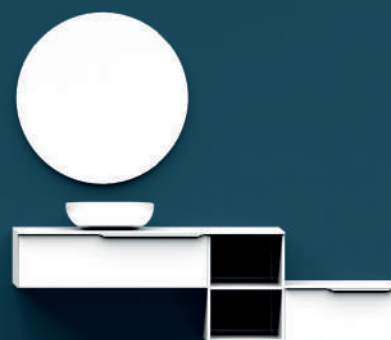

MIO 17





# 1-2

/Familia Pons

/Anna Costa

/Julia y Jorge



# Estética y funcionalidad se dan la mano.

---

*ES\_Wave, un diseño para verdaderos amantes de la innovación. Actualizamos las líneas redondeadas del mueble con una curvatura suave e introducimos un tirador integrado en el mismo material que el resto del mueble. Sorprendente, original y sofisticado.*

*EN\_Wave, a design for true admirers of innovation. We update the rounded lines of the unit with a gentle curve and add a fixed handle of the same material as the rest of the piece. Surprising, original and sophisticated.*

*EN\_ Aesthetics and functionality hand by hand.*

*FR\_Esthétique et fonctionnalité vont de pair.*

*IT\_Estetica e funzionalità si incontrano.*

—

*FR\_Wave, un design pour les vrais amateurs d'innovation. Nous avons mis à jour les lignes arrondies du mobilier avec une courbure douce et avons introduit une poignée intégrée dans le même matériau que le reste du mobilier. Surprenant, original et sophistiqué.*

*IT\_Wave, un design per i veri amanti dell'innovazione. Abbiamo modificato le linee rotondeggianti del mobile con una curvatura dolce ed abbiamo inserito una maniglia integrata dello stesso materiale del mobile. Sorprendente, originale e sofisticato.*

# Familia Pons

Noemí (38) y Ainhoa (1) son una madre y una hija que viven en Valencia. Noemí aprovecha que su empresa le permite trabajar a distancia tres días a la semana para conciliar su vida profesional y personal. Desde que Ainhoa llegó a su vida su presencia es evidente, con una pequeña invasión en cada rincón de la casa. El día de ambas acaba siempre con el baño de Ainhoa en el lavabo.

## ¿Cómo organizas tu jornada laboral?

Me despierto pronto para arreglarme en el baño. Esos minutos en el baño son un pequeño tesoro diario que tengo. Luego desayuno con Ainhoa y la llevo al jardín de infancia. Trabajo intensamente por la mañana y la recojo a mediodía. Por la tarde trabajo cuando ella me deja.

## Y en la casa, ¿ha habido muchos cambios?

Lo primero que notas cuando entras en nuestra casa es que hay cosas de Ainhoa por todas partes. Organizarlo es una cuestión de ingenio, por ejemplo en el baño he instalado otro camerino para tener más espacio de almacenamiento.

## Hablando del baño, ¿cómo te organizas?

A mí me encanta bañar a Ainhoa en el lavabo. Me recuerda mucho a mi infancia y ella se lo pasa pipa.

*EN\_Noemí (38) and Ainhoa (1) are a mother and daughter who live in Valencia. Noemí's company lets her work remotely three days a week, allowing her to combine her professional and personal life. Ever since Ainhoa arrived in her life her presence is obvious, with a little onslaught in every corner of the house. Their days always finish with Ainhoa taking a bath in the sink.*

*FR\_Noemí (38 ans) est une mère qui vit avec sa fille Ainhoa (1 an) à Valence. Noemí profite du fait que son entreprise lui permet de travailler à distance trois jours par semaine pour concilier sa vie professionnelle avec sa vie personnelle. Depuis qu'Ainhoa est entrée dans sa vie, sa présence est évidente, avec une petite invasion dans chaque coin de la maison. La journée des deux se termine toujours par le bain d'Ainhoa au lavabo.*

*IT\_Noemí (38) e Ainhoa (1) sono madre e figlia che vivono a Valencia. Noemí approfitta del fatto che la sua azienda le consent di lavorare da casa tre volte alla settimana per conciliare la sua vita professionale con quella privata. Da quando Ainhoa è arrivata nella sua vita, la sua presenza è evidente, con una piccola invasione in ogni angolo della casa. La giornata di entrambe termina sempre con il bagno di Ainhoa nel lavandino.*



July  
21  
22  
23  
24  
25  
26  
27

+

o









# FAMILIA PONS



ES\_Un espacio para conectar./ EN\_A space to connect.  
FR\_Un espace pour se connecter./ IT\_Uno spazio per connettersi.

# Anna Costa

Anna Costa (35) trabaja como consultora de políticas sociales en Bruselas donde vive de lunes a viernes. Sus grandes pasiones son viajar los fines de semana y se reconoce una estudiante eterna, por lo que siempre busca nuevas formas de aprender sobre cualquier tema. A lo que no puede renunciar Anna es a su ritual matutino que la ayuda a afrontar el día, para ello usa su lavabo a modo de tocador, donde dispone las cremas y complementos que necesita cada mañana.

## ¿Cómo empiezas el día?

Me despierto con tiempo para poder prepararme tranquilamente en el baño. En el lavabo tengo mi set de cremas faciales y sérum, que es mi ritual para empezar con energía el día... Eso y un café, ¡claro!

## ¿Cuál ha sido tu último viaje?

Me encanta ir en moto, así que aproveché el fin de semana pasado para ir a Gante, una ciudad preciosa llena de rincones especiales.

## ¿Cuál es el último curso que has hecho?

Un curso sobre liderazgo y creatividad impartido por Anna Wintour de Vogue, en MasterClass, una plataforma a la que soy una auténtica adicta.

*EN\_Aнна Costa (35) works as a social policy consultant in Brussels where she lives from Monday to Friday. Her big passion is travelling on weekends, and she sees herself as an eternal student, always looking for new ways to learn about any subject. What Anna can't give up is her morning ritual which helps her face the day, so she uses her sink as a dressing table where she keeps the creams and accessories she needs every morning.*

*FR\_Aнна Costa (35 ans) travaille comme consultante en politique sociale à Bruxelles où elle vit du lundi au vendredi. Les voyages du week-end sont sa grande passion, et elle se reconnaît comme une éternelle étudiante, toujours à la recherche de nouvelles façons d'apprendre sur n'importe quel sujet. Ce qu'Anna ne peut pas abandonner, c'est son rituel du matin, qui l'aide à affronter la journée. Elle se sert de son évier comme d'une coiffeuse, où elle dispose des crèmes et des accessoires dont elle a besoin chaque matin.*

*IT\_Aнна Costa (35) lavora come consulente nell'ambito delle politiche sociali a Bruxelles dove vive dal lunedì al venerdì. Le sue grandi passioni sono viaggiare nei fine settimana. Si definisce un'eterna studentessa, per cui cerca sempre nuovi modi per imparare qualsiasi argomento. Ciò a cui Anna non può rinunciare è il suo rituale mattutino che l'aiuta ad affrontare la giornata, per questo usa il suo lavabo come toletta, su cui dispone creme e accessori di cui hai bisogno ogni mattina.*









# ANNA



ES\_Pequenos rituales para hacer grandes cosas.  
EN\_Little rituals to do big things.  
FR\_De petits rituels pour faire de grandes choses.  
IT\_Piccoli rituali per fare grandi cose.

# COSTA

# Julia y Jorge

Julia (26) y Jorge (24) son una pareja de León que se conoció en Tinder. Lo suyo fue amor a primera vista y desde ese primer encuentro se volvieron inseparables. Después de tres años de relación se mudaron juntos. Ella es diseñadora y él ingeniero, lo que queda plasmado en su casa, de diseño ultra moderno y donde la tecnología está presente en cada rincón.

## ¿Un gadget sin el que no podéis vivir?

Cada vez estamos más enganchados a Alexa. Es súper útil, pero sobre todo, muy divertido.

## ¿Un deseo vital?

El próximo año queremos viajar a Japón, nos alucina su cultura y tenemos ganas de conocer de primera mano Tokio.

## ¿Una app sin la que no podéis vivir?

La que más usamos los dos... ¡Spotify sin duda! Seguro que los vecinos lo saben porque nos encanta cantar en la ducha y jugar a programas de talentos musicales. La ronda de jurado la hacemos al salir ante el espejo antivaho del baño, ¡que no se empaña!

*EN\_Julia (26) and Jorge (24) are a couple from León who met on Tinder. They fell in love at first sight and they became inseparable from the first date. After three years in a relationship they moved in together. She is a designer and he is an engineer, which is expressed in their house where ultra modern design meets technology present in every corner.*

*FR\_Julia (26 ans) et Jorge (24 ans) sont un couple de León qui s'est rencontré sur Tinder. Pour eux, ça a été tout de suite le coup de foudre et dès cette première rencontre, ils sont devenus inséparables. Après trois ans de relation, ils ont décidé de vivre ensemble. Elle est designer et lui ingénieur, ce qui se reflète dans leur maison, au design ultra-moderne et où la technologie est présente dans tous les coins.*

*IT\_Julia (26) e Jorge (24) sono una coppia di Leon che si è conosciuta su Tinder. Il loro è stato amore a prima vista e dal loro primo incontro sono diventati inseparabili. Dopo tre anni di relazione sono andati a vivere insieme. Lei è designer e lui ingegnere, cosa che si riflette nella sua casa, con un design ultra moderno e la tecnologia è presente in ogni angolo.*









# JULIA Y JORGE

ES\_Diseño y tecnología en cada rincón.  
EN\_Design and technology in every corner.  
FR\_Design et technologie dans chaque coin.  
IT\_Design e tecnologia in ogni angolo.



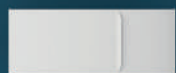
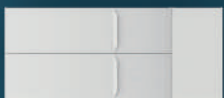
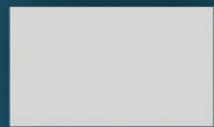
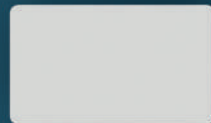

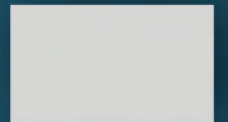
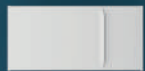
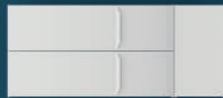
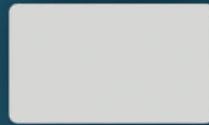



WAVE 04



WAVE 05

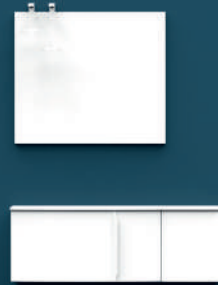

WAVE 06



WAVE 07



WAVE 08



WAVE 09





WAVE 10



WAVE 11



WAVE 12



WAVE 13



WAVE 14



WAVE 15



# 1-3

/Familia Ruix

/Ramona Torres

/Luci, Álex y

Frederika

/Hugo y Esther



Elige módulos,  
acabados,  
lavabos y  
espejos  
creando un  
mueble que es  
solo tuyo.

---

*ES\_Nuestra opción más minimalista: Vida es un diseño que resiste las modas pasajeras. Un mueble de aspecto fresco que se adapta a cualquier espacio y estilo de forma eficiente y accesible.*

*EN\_Our most minimalist option: Vida is a design that is beyond passing fashions. A fresh-looking piece that can adapt to any space and style efficiently and accessibly.*

*EN\_Choose modules, finishes,  
washbasins, mirrors and create a piece  
that is uniquely yours.*

*FR\_Choisissez des modules, des finitions,  
des vasques, des miroirs et créez un  
meuble qui vous appartient.*

*IT\_Scegli moduli, finiture, lavabi, specchi  
e crea un mobile che sia solo tuo.*

—

*FR\_Notre option la plus minimaliste : Vida est un design  
qui résiste aux modes passagères. Un meuble au look  
frais qui s'adapte à tout espace et à tout style de  
manière efficace et accessible.*

*IT\_La nostra opzione più minimalista: Vida ha un design  
che resiste alle mode passeggere del momento. Un  
mobile dall'aspetto fresco che si adatta a qualunque  
spazio e stile di vita in maniera efficiente ed accessibile.*

# Familia Ruix

Luis (38) y Amparo (39) tienen tres hijos: Ana (11), María (9) y Juanjo (5). Entre semana Maribel (62), la madre de Luis, se instala en su casa para echarles una mano, ya que ambos trabajan. La Familia Ruix ha aprendido a vivir en el caos. Aunque a veces se tiren los trastos a la cabeza, el jaleo también es parte de lo que más les gusta de su casa, siempre hay alguien para compartir unas risas o que te eche una mano. Cada noche se cepillan los dientes juntos y acaban el día en el mismo lugar donde empieza. El baño para ellos es también un espacio de reunión familiar.

## Siendo tantos, ¿cómo os organizáis para usar el baño?

Tenemos dos, en el grande hemos puesto un mueble con 3 lavabos para poder usarlo varios a la vez. Así hay menos riñas por entrar. Pero lo más complicado es conseguir que todos nuestros hijos se laven los dientes por la noche. Para dar ejemplo, lo hacemos los 5 juntos. Es un poco loco, ¡pero muy divertido!

## ¿Un plan en familia?

Todos los domingos por la tarde vemos una película juntos. Cada semana elige uno.

*EN\_Luis (38) and Amparo (39) have three children: Ana (11), María (9) and Juanjo (5). On weekdays Maribel (62), Luis' mother, comes to lend them a hand because they both work. The Ruix family has learned how to live in chaos. Although they have rows from time to time, the racket is part of what they like most about their house: there's always someone to share laughs with or lend you a hand. Every night they brush their teeth together and they end the day in the same place as it starts. For them, the bathroom is also a family meeting room.*

*FR\_Luis (38 ans) et Amparo (39 ans) ont trois enfants : Ana (11 ans), María (9 ans) et Juanjo (5 ans). Pendant la semaine, Maribel (62 ans), la mère de Luis, s'installe dans leur maison pour leur donner un coup de main, puisque tous deux travaillent. La famille Ruix a appris à vivre au milieu du chaos. Même si parfois ils se disputent, le bruit fait aussi partie de ce qu'ils aiment le plus dans leur maison. Il y a toujours quelqu'un pour partager quelques rires ou donner un coup de main. Chaque soir, ils se brossent les dents ensemble et terminent la journée au même endroit où elle commence. La salle de bains est également un espace où la famille se retrouve.*

*IT\_Luis (38) e Amparo (39) hanno tre figli: Anna (11), María (9) e Juanjo (5). Durante la settimana, Maribel (62), la madre di Luis, va a stare da loro per dare una mano, visto che entrambi lavorano. La Famiglia Ruix ha imparato a vivere nel caos. Anche se a volte litigano, la confusione fa parte di ciò che più amano della loro casa: c'è sempre qualcuno con cui condividere delle risate o che dà una mano. Ogni sera, si lavano i denti insieme e terminano la giornata nello stesso luogo dove è iniziata. Il bagno per loro è anche uno spazio di ritrovo per la famiglia.*











## FAMILIA RUIX



ES\_El punto de encuentro para empezar el día.  
EN\_The meeting point to begin the day.  
FR\_Le point de rencontre pour commencer la journée.  
IT\_Il punto di incontro per iniziare la giornata.

# Ramona Torres

Ramona Torres (79) se mudó con su hija y su marido a San Sebastián hace unos años, a causa de sus dificultades de movilidad. En la planta baja tiene una habitación con baño propio que reformaron antes de su llegada para hacerlo más accesible. A pesar de todo Ramona ha aprendido a vivir con sus limitaciones. Es activa y sale todos los días de casa, acompaña a su hija al mercado a comprar y se reúne dos días por semana con un grupo de costura, donde también ayuda a jóvenes que quieren aprender a coser.

## ¿Un placer culpable?

De vez en cuando me permito tomarme un vermut antes de comer.

## ¿Lo mejor de San Sebastián?

Me dio pena dejar Madrid, pero San Sebastián es preciosa y la playa es increíble.

## ¿Lo mejor para mantenerse saludable?

Estar activa siempre, hacer algo cada día. Y no tener miedo de probar cosas nuevas de vez en cuando.

*EN\_Ramona Torres (79) moved in with her daughter and her husband in San Sebastián a few years ago because of mobility problems. On the ground floor there is a room with an en-suite bathroom which they renovated before she came to make it more accessible. Despite everything, Ramona has learned to live with her limitations. She is active and leaves the house every day, she goes to the market with her daughter and she meets with a sewing group two days a week, where she also helps young people who want to learn how to sew.*

*FR\_Ramona Torres (79 ans) a déménagé avec sa fille et son mari à San Sebastián il y a quelques années, en raison de ses difficultés de mobilité. Au rez-de-chaussée, elle dispose d'une chambre avec sa propre salle de bains qu'ils ont rénovée avant leur arrivée pour la rendre plus accessible. Malgré tout, Ramona a appris à vivre avec ses limites. Elle est active et quitte la maison tous les jours, accompagne sa fille au marché pour faire ses courses et se réunit deux jours par semaine avec un groupe de couture, où elle aide également les jeunes qui veulent apprendre à coudre.*

*IT\_Ramona Torres (79) si è trasferita con sua figlia e suo marito a San Sebastián qualche anno fa, a causa delle sue difficoltà motorie. Al piano terra hanno una stanza con bagno che hanno ristrutturato prima del loro arrivo per renderlo più accessibile. Nonostante tutto, Ramona ha imparato a convivere con i suoi limiti. È attiva ed esce tutti i giorni di casa, accompagna sua figlia al mercato a fare compere e si riunisce due volte a settimana con un gruppo di cucito, dove aiuta i giovani che vogliono imparare a cucire.*







# RAMONA TORRES







ES\_Ella se acepta, el baño se adapta.  
EN\_She accepts herself, the bathroom adapts itself.  
FR\_Elle s'accepte, la salle de bain s'adapte.  
IT\_Lei si accetta, il bagno si adatta.

# Luci, Álex y Frederika

Luci (24) y Álex (24) se conocen desde el instituto y cuando se fueron a vivir a Barcelona para estudiar en la universidad decidieron buscar un piso juntos. En la habitación libre que tienen acogen a estudiantes de todos los países del mundo, lo que les ofrece la oportunidad de practicar inglés. Ahora vive con ellos Frederika (27), una estudiante de arte que realiza un doctorado sobre arquitectura gótica en la ciudad condal.

## ¿Cómo os organizáis en casa?

Cada uno tiene horarios diferentes, por lo que es complicado. Tenemos una hoja en la nevera para repartir tareas.

## Y los turnos de baño, ¿cómo funcionan?

Tenemos mucha suerte porque en casa la ducha y el lavabo están separados, por lo que es más fácil organizarse. Eso sí, hemos establecido un tiempo límite de 10 minutos para la ducha. Es más sostenible y así nos da tiempo a ducharnos todos por la mañana.

*EN\_Luci (24) and Álex (24) have known each other from high school, and when they went to study at university in Barcelona they decided to look for a flat together. In their spare room they welcome students from countries all over the world, which gives them the opportunity to practise their English. Now Frederika (27) lives with them, an art student doing a doctorate in Gothic architecture in Barcelona.*

*FR\_Luci (24 ans) et Álex (24 ans) se connaissent depuis le lycée et lorsqu'ils sont allés vivre à Barcelone pour étudier à l'université, ils ont décidé de chercher un appartement ensemble. Dans la pièce libre dont ils disposent, ils accueillent des étudiants du monde entier, ce qui leur donne l'occasion de pratiquer l'anglais. Frederika (27 ans), une étudiante en art qui prépare un doctorat en architecture gothique à Barcelone, vit maintenant avec eux.*

*IT\_Luci (24) ed Álex (24) si conoscono dai tempi del liceo e quando si sono trasferiti a Barcellona per studiare all'università, hanno deciso di cercare un appartamento in cui vivere insieme. Nella stanza libera di cui dispongono, ospitano studenti di tutti i Paesi del mondo, gli consentendogli di praticare la lingua inglese. Ora con loro vive Frederika (27), una studentessa di arte che fa il dottorato in architettura gotica nel capoluogo della Catalogna.*







# LUCI, ÁLEX Y FREDERIKA



ES\_Compartir es vivir./ EN\_Sharing is living.  
FR\_Partager, c'est vivre./ IT\_Condividere è vivere.



# Hugo y Esther

¡Barco pirata a la vista! ¡Cuidado con los hipopótamos! ¡A surfear!... Cuando Hugo (4) y Esther (4) se ponen a imaginar no hay límites. Su sitio preferido es el baño, donde pueden jugar con agua y hacer que son bucaneros o vigilantes de la playa. Durante esos momentos se trasladan a lugares mágicos y se olvidan de todo lo demás.

¿Cuál es vuestra próxima aventura?

Vamos a buscar un tesoro en un barco hundido.

Si pudierais pedir un deseo, ¿cuál sería?

Tener un mono para nuestro barco pirata, claro.

¿Cuál es vuestro recuerdo más feliz?

¡Cuando cumplimos 4 años! Vinieron todos nuestros amigos a casa para jugar. Hicimos un fuerte con sillas y sábanas en toda la casa.

*EN\_Pirate ship on the horizon! Watch out for the hippopotamuses! Let's go surfing!... When Hugo (4) and Esther (4) let their imagination run wild, they know no limits. Their favourite place is the bathroom, where they can play with water and become pirates or lifeguards. During these moments, they are transported to magical places and they forget everything else.*

*FR\_Bateau pirate en vue ! Attention aux hippopotames ! Allons surfer ! Quand Hugo (4 ans) et Esther (4 ans) commencent à imaginer qu'il n'y a pas de limites. Leur endroit préféré est la salle de bains, où ils peuvent jouer dans l'eau et se faire passer pour des boucaniers ou des gardiens de plage. Pendant ces moments, ils se déplacent dans des lieux magiques et oublient tout le reste.*

*IT\_ Nave pirata in vista! Attenti agli ippopotami! Facciamo surf!... Quando Hugo (4) ed Esther (4) iniziano a fantasticare non ci sono limiti. Il loro posto preferito è il bagno, dove possono giocare con l'acqua e immaginare di essere pirati o bagnini. In quei momenti, evadono in posti magici e si dimenticano del resto.*







## HUGO Y ESTHER



ES\_Una historia en cada baño.  
EN\_A story in every bath.  
FR\_Une histoire dans chaque salle de bains.  
IT\_C'è una storia in ogni bagno.



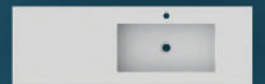
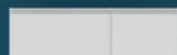
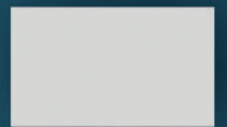
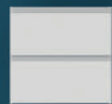
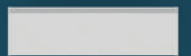
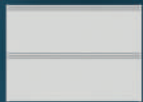
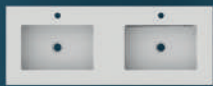
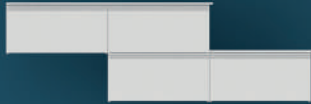
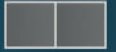
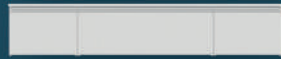



VIDA 05



VIDA 06



VIDA 07



VIDA 08



VIDA 09



VIDA 10



VIDA 11



VIDA 12



VIDA 13



VIDA 14



VIDA 15

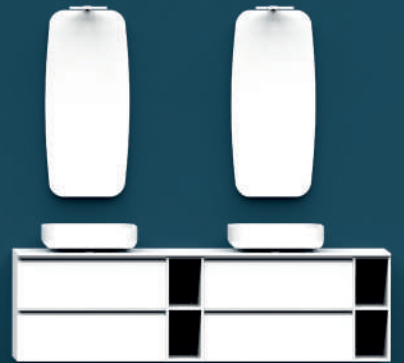

VIDA 16





TECHNIQUE/ TECNI  
CO/ TÉCNICO/ TECHNICAL/ TÉCNICO/ TECHNICAL/ CAL/ TECHNIQUE/  
CAL/ TECHNIQUE/

## Iconografía/ Iconography/ Iconographie/ Iconografia

### Lavabos/ Washbasins/ Plan vasques/ Lavabi



Lavabo cerámico/ Ceramic washbasin  
Plan vasque céramique/ Lavabo in ceramica



Lavabo mineral cover/ Mineral cover washbasin  
Plan vasque mineral cover/ Lavabo mineral cover

### Luces/ Lights/ Lumières/ Illuminazione



Luz LED/ LED light  
Lumière LED/ Luce LED



IP44  
CLASS II

### Espejos/ Mirrors/ Miroirs/ Specchi



Sensor On-Off/ On-Off sensor  
Sensitif On-Off/ Sensore On-Off



Espejo antivaho/ Anti-fog mirror  
Miroir antibuée/ Specchio antiappannamento



Espejo luz integrada/ Integrated lighting  
Miroir avec lumière intégrée/ Luce LED integrada

### Acabados/ Finishes/ Finitions/ Finiture



Melamina/ Melamine  
Mélamine/ Melamina



Lacado alto brillo/ High gloss lacquered  
Laqué haute brillance/ Laccato super brillante



Recubrimiento 2D/ Wrapping foil in 2D  
Revêtement 2D/ Rivestimento 2D



Lacado mate/ Matt lacquered  
Laqué mat/ Laccato mat



Recubrimiento 3D/ Wrapping foil in 3D  
Revêtement 3D/ Rivestimento 3D

### Aperturas/ Opening/ Ouvertures/ Apertura



Cajón extracción total/ Fully removable drawers  
Tiroirs extraction totale/ Cassetti a estrazione totale



Apertura a la izquierda/ Opening to the left  
Ouverture à gauche/ Apertura a sinistra



Sistema soft close/ Soft close system  
Système soft close/ Sistema soft close



Apertura a la derecha/ Opening to the right  
Ouverture à droite/ Apertura a destra



Apertura-cierre push/ Push opening-closing  
Ouverture-fermeture push/ Apertura-chiusura push



Apertura de puertas central/ Opening of central doors  
Ouverture portes centrale/ Apertura delle porte centrale

## Nomenclatura/ Nomenclature/ Nomenclature/ Nomenclatura

P.  
Puerta/ Door/ Portes/ Porta

IZD  
Izquierda/ Left/ Gauche/ Sinistra

H.  
Altura/ Height/ Hauteur/ Altezza

C.  
Cajón/ Drawer/ Tiroirs/ Cassetti

DCH  
Derecha/ Right/ Droite/ Destra

S.  
Seno / Sink / Bac / Vasca

Ref.  
Referencia/ Reference/ Référence/ Referenza

ES\_Las medidas se representan en centímetros.  
EN\_These products are measured in centimetres.  
FR\_Les dimensions sont indiquées en cm.  
IT\_Le misure sono espresse in centimetri.

# INFORMACIÓN TÉCNICA

*Technical information*  
*Information technique*  
*Informazioni tecniche*

---

- 112 MIO
- 120 WAVE
- 124 VIDA
- 132 ESPEJOS/ MIRRORS  
MIROIRS/ SPECCHI
- 136 LUMINARIAS LED/ LED WALL LIGHT  
LUMINAIRES LED/ ILLUMINAZIONE LED
- 138 ACCESORIOS/ ACCESSORIES  
ÉLÉMENTS COMMUNS/ ACCESSORI
- 140 ACABADOS/ FINISHES  
FINITIONS/ FINITURE

## MUEBLE

Furniture/ Meuble/ Mobile

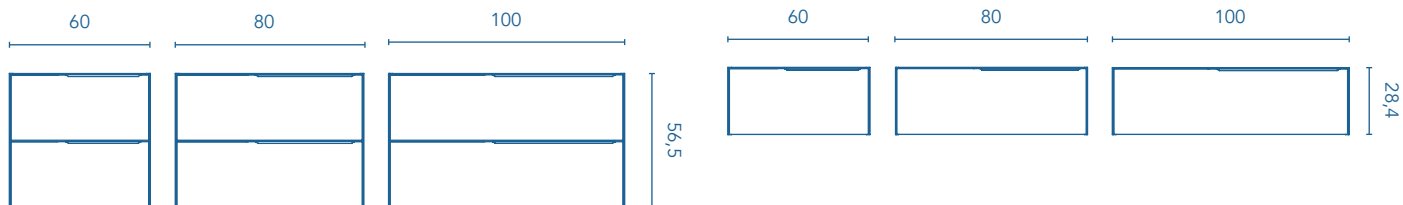

Profundidad 45/ Depth 45/ Profondeur 45/ Profondità 45.



60 2C	80 2C	100 2C	60 1C	80 1C	100 1C	Acabados/ Finishes/ Finitions/ Finiture	Tiradores/ Handles/ Poignées/ Maniglie
Ref. 126350	Ref. 126355	Ref. 126360	Ref. 126365	Ref. 126370	Ref. 126375	● RO8	● Arena/ Sand/ Sable/ Sabbia
Ref. 126351	Ref. 126356	Ref. 126361	Ref. 126366	Ref. 126371	Ref. 126376	● OL1	● Arena/ Sand/ Sable/ Sabbia
Ref. 126352	Ref. 126357	Ref. 126362	Ref. 126367	Ref. 126372	Ref. 126377	● MA15M	● Arena/ Sand/ Sable/ Sabbia
Ref. 126349	Ref. 126354	Ref. 126359	Ref. 126364	Ref. 126369	Ref. 126374	○ BL20M	● Negro/ Black/ Noir/ Nero
Ref. 126348	Ref. 126353	Ref. 126358	Ref. 126363	Ref. 126368	Ref. 126373	○ BL20M	○ Blanco/ White/ Blanc/ Bianco

ES\_Mueble con salva sifón y organizador de cajón.  
 EN\_Unit with drain protection and drawer organizer.  
 FR\_Meuble avec découpe siphon et organisateur de tiroir.  
 IT\_Mobile con salva sifone e organizer da cassetto.

## BAJO

Base unit/ Meuble bas/ Mobile basso

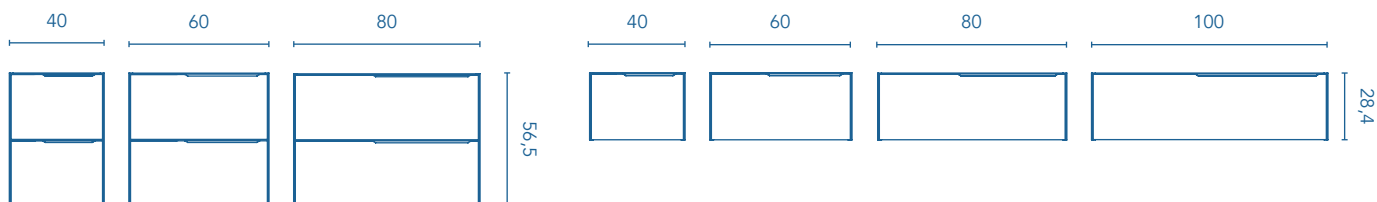

Profundidad 45/ Depth 45/ Profondeur 45/ Profondità 45.



40 2C	60 2C	80 2C	40 1C	60 1C	80 1C	100 1C	Acabados/ Finishes/ Finitions/ Finiture	Tiradores/ Handles/ Poignées/ Maniglie
Ref. 126380	Ref. 126385	Ref. 126390	Ref. 126395	Ref. 126400	Ref. 126405	Ref. 126410	● RO8	● Arena/ Sand/ Sable/ Sabbia
Ref. 126381	Ref. 126386	Ref. 126391	Ref. 126396	Ref. 126401	Ref. 126406	Ref. 126411	● OL1	● Arena/ Sand/ Sable/ Sabbia
Ref. 126382	Ref. 126387	Ref. 126392	Ref. 126397	Ref. 126402	Ref. 126407	Ref. 126412	● MA15M	● Arena/ Sand/ Sable/ Sabbia
Ref. 126379	Ref. 126384	Ref. 126389	Ref. 126394	Ref. 126399	Ref. 126404	Ref. 126409	○ BL20M	● Negro/ Black/ Noir/ Nero
Ref. 126378	Ref. 126383	Ref. 126388	Ref. 126393	Ref. 126398	Ref. 126403	Ref. 126408	○ BL20M	○ Blanco/ White/ Blanc/ Bianco

ES\_Mueble auxiliar, sin salva sifón ni organizador de cajón.  
 EN\_Auxiliary unit, without drain protection and drawer organizer.  
 FR\_Meuble auxiliaire, sans découpe siphon ni organisateur de tiroir.  
 IT\_Mobile ausiliario, senza salva sifone e organizer da cassetto.

## MÓDULO ABIERTO

Open module/ Module ouvert/ Modulo aperto

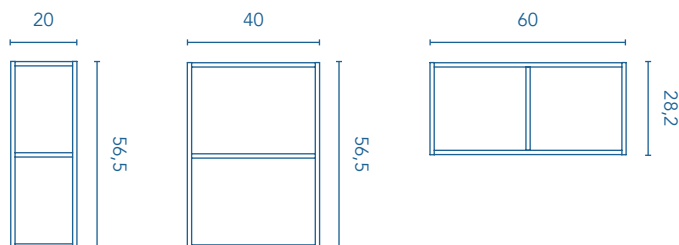

Profundidad 45/ Depth 45/ Profondeur 45/ Profondità 45.

20	40	60	Acabados/ Finishes/ Finitions/ Finiture
Ref. 126415	Ref. 126418	Ref. 126421	Arena/ Sand/ Sable/ Sabbia
Ref. 126414	Ref. 126417	Ref. 126420	Negro/ Black/ Noir/ Nero
Ref. 126413	Ref. 126416	Ref. 126419	Blanco/ White/ Blanc/ Bianco

## ALTO

Wall unit/ Meuble haut/ Alto



Profundidad 20/ Depth 20  
Profondeur 20/ Profondità 20.



1P DCH	1P IZD	Acabados/ Finishes/ Finitions/ Finiture
Ref. 126423	Ref. 126717	RO8
Ref. 126424	Ref. 126718	OL1
Ref. 126425	Ref. 126719	MA15M
Ref. 126422	Ref. 126716	BL20M

ES\_Interior: 2 estantes de cristal.  
EN\_Interior: 2 glass shelves.  
FR\_Intérieur: 2 étagères en verre.  
IT\_Interno: 2 mensole di vetro.

## COLUMNNA

Column/ Colonne/ Colonna

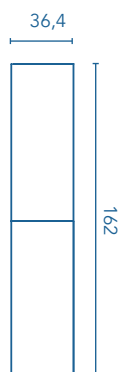

Profundidad 24/ Depth 24  
Profondeur 24/ Profondità 24.



2P DCH	2P IZD	Acabados/ Finishes/ Finitions/ Finiture
Ref. 126427	Ref. 126721	RO8
Ref. 126428	Ref. 126722	OL1
Ref. 126429	Ref. 126723	MA15M
Ref. 126426	Ref. 126720	BL20M

ES\_Interior: 4 estantes móviles de cristal y 1 estante fijo de madera.  
EN\_Interior: 4 mobile glass shelves and 1 fixed wooden shelf.  
FR\_Intérieur: 4 étagères amovibles en verre et 1 étagère fixe en bois.  
IT\_Interno: 4 mensole rimuovibili di vetro e 1 mensola fissa in legno.

## ACABADOS

Finishes/ Finitions/ Finiture



RO8: Roble blanco/  
White oak/ Coloris  
chêne blanc/ Rovere  
bianco

OL1: Olmo gris/  
Grey elm/ Orme  
gris/ Olmo grigio

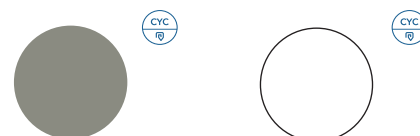

MA15M: Arena mate/  
Sand matt finish/ Sable  
mat/ Sabbia matte

BL20M: Blanco mate/  
Matt white/ Blanc mat/  
Bianco opaco

ES\_Códigos sombreados en stock.  
EN\_Shaded codes are in stock.  
FR\_Les codes surlignés sont en stock.  
IT\_I codici ombreggiati sono in stock.

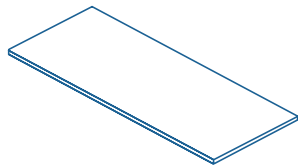
**TAPAS****Tops/ Couvercle/ Tops**

Profundidad 46/ Depth 46/ Profondeur 46/ Profondità 46.  
 Espesor 1,6/ Thickness 1,6/ Épaisseur 1,6/ Spessore 1,6.

40	60	80	100	120	140	160	180	200	Acabados/ Finishes/ Finitions/ Finiture
Ref. 126431	Ref. 126435	Ref. 126439	Ref. 126443	Ref. 126447	Ref. 126451	Ref. 126455	Ref. 126459	Ref. 126463	RO8
Ref. 126432	Ref. 126436	Ref. 126440	Ref. 126444	Ref. 126448	Ref. 126452	Ref. 126456	Ref. 126460	Ref. 126464	OL1
Ref. 126433	Ref. 126437	Ref. 126441	Ref. 126445	Ref. 126449	Ref. 126453	Ref. 126457	Ref. 126461	Ref. 126465	MA15M
Ref. 126430	Ref. 126434	Ref. 126438	Ref. 126442	Ref. 126446	Ref. 126450	Ref. 126454	Ref. 126458	Ref. 126462	BL20M

ES\_No admite lavabo.  
 EN\_Doesn't admit washbasin.  
 FR\_N'accepte pas de plan vasque.  
 IT\_Non prevede lavabo.

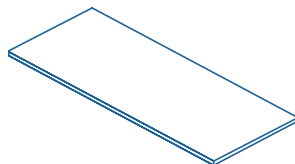
**ENCIMERAS****Worktops/ Plans/ Tops per lavabo**

Profundidad 46/ Depth 46/ Profondeur 46/ Profondità 46.  
 Mineral cover - Espesor 1,2/ Thickness 1,2/ Épaisseur 1,2/ Spessore 1,2.  
 Marble stone - Espesor 2/ Thickness 2/ Épaisseur 2/ Spessore 2.  
 Concretech - Espesor 1,5/ Thickness 1,5/ Épaisseur 1,5/ Spessore: 1,5.

60	80	100	120	140	160	180	200	Acabados/ Finishes/ Finitions/ Finiture
Ref. 126291	Ref. 126292	Ref. 126293	Ref. 126294	Ref. 126295	Ref. 126296	Ref. 126297	Ref. 126298	Mineral cover
Ref. 126307	Ref. 126308	Ref. 126309	Ref. 126310	Ref. 126311	Ref. 126312	Ref. 126313	Ref. 126314	Marble stone
Ref. 126299	Ref. 126300	Ref. 126301	Ref. 126302	Ref. 126303	Ref. 126304	Ref. 126305	Ref. 126306	Concretech

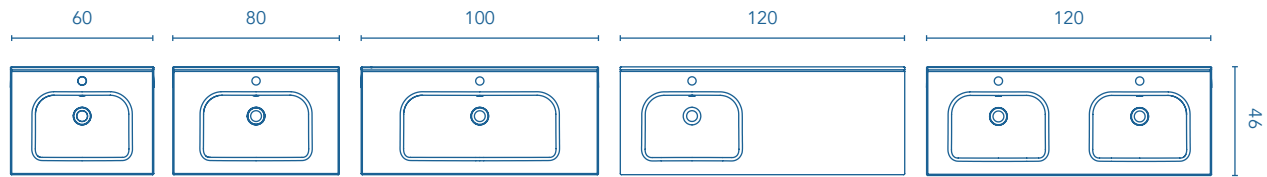
**SLIM\_LAVABO INTEGRADO CERÁMICO***Built-in ceramic washbasin/ Plan vasque intégrée céramique/ Lavabo integrato in ceramica*

Acabado brillo/ Gloss finish/ Finition brillante/ Finitura lucida.  
 Profundidad del seno 12,5/ Sink depth 12,5/ Profondeur du bac 12,5/ Profondità della vasca 12,5.  
 Espesor 2/ Thickness 2/ Épaisseur 2/ Spessore 2.



SLIM	60	80	100	120 1S IZD	120 2S
	Ref. 123341	Ref. 123343	Ref. 123344	Ref. 125316	Ref. 123345



ES\_Códigos sombreados en stock.  
 EN\_Shaded codes are in stock.  
 FR\_Les codes surlignés sont en stock.  
 IT\_I codici ombreggiati sono in stock.

## SKY\_ENCIMERA CON LAVABO INTEGRADO MINERAL COVER NEW

Worktop with built-in mineral cover washbasin/ Plan vasque intégrée mineral cover/ Top lavabo integrato mineral cover

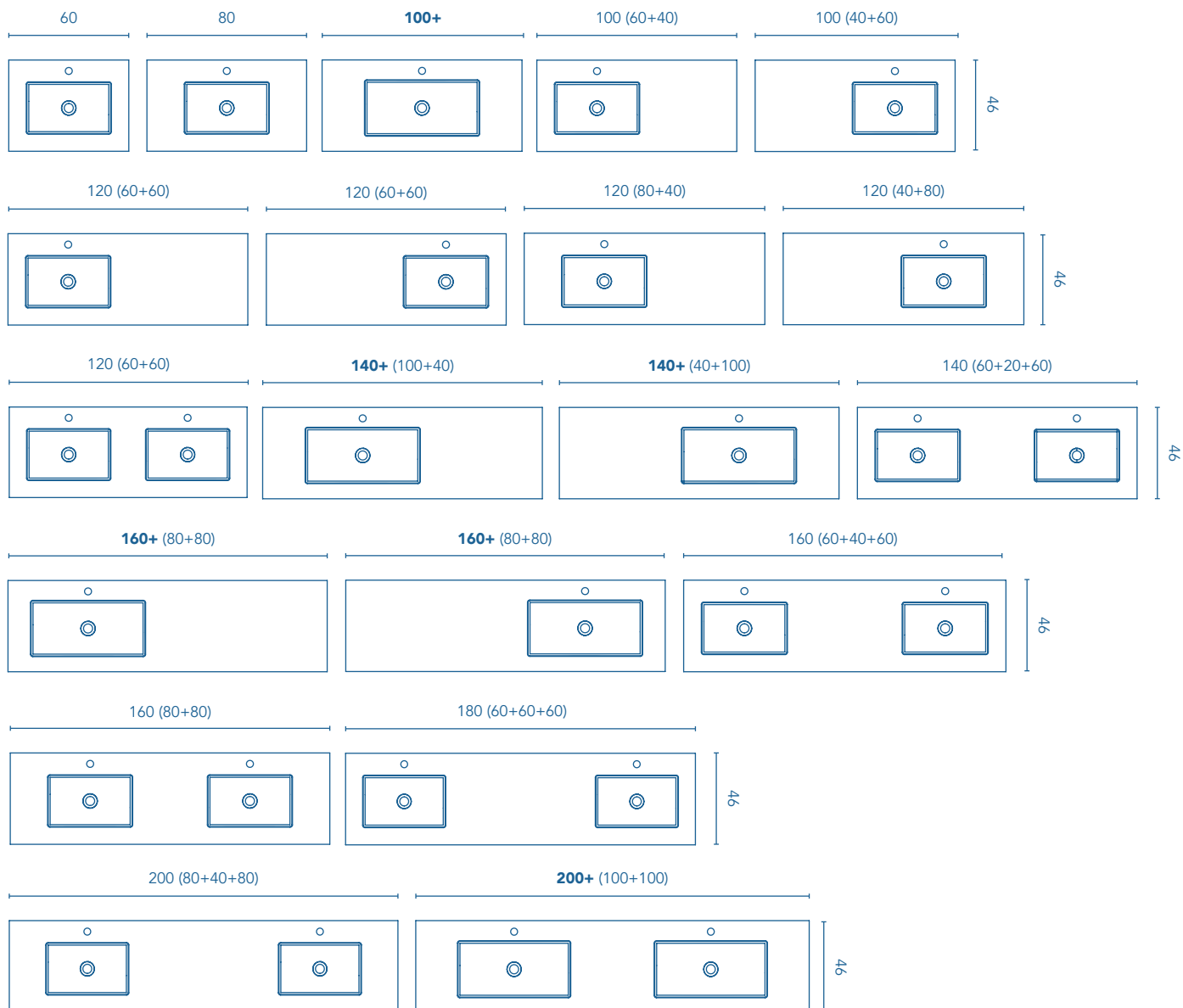

ES\_Las medidas entre paréntesis especifican los módulos necesarios para dicha composición.

EN\_The measures given in parenthesis indicate the units necessary for this composition.

FR\_Les dimensions entre parenthèse indiquent les modules nécessaires pour la composition.

IT\_Le misure in parentesi specificano i moduli necessari per l'utilizzo del lavabo relativo.



Tamaño seno/ Sink size/ Taille du bac/ Dimensione della vasca.

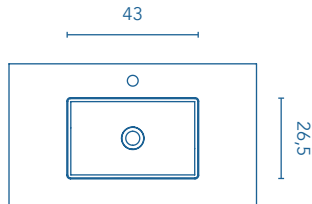

Tamaño seno +/- Sink size +/- Taille du bac +/- Dimensione della vasca +.

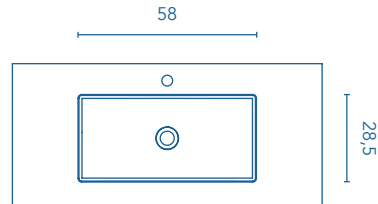

Acabado mate/ Matt finish/ Finition mat/ Finitura opaca.  
 Profundidad del seno 12/ Sink depth 12/ Profondeur du bac 12/ Profondità della vasca 12.  
 Espesor 1,2/ Thickness 1,2/ Épaisseur 1,2/ Spessore 1,2.



SKY	60	80	100+	100 1S IZD (60+40)	100 1S DCH (40+60)	
	Ref. 126267	Ref. 126268	Ref. 126269	Ref. 126753	Ref. 126754	○
	<b>120 1S IZD (60+60)</b>	<b>120 1S DCH (60+60)</b>	<b>120 1S IZD (80+40)</b>	<b>120 1S DCH (40+80)</b>	<b>120 2S (60+60)</b>	○
	Ref. 126270	Ref. 126271	Ref. 126755	Ref. 126756	Ref. 126272	○
	<b>140+ 1S IZD (100+40)</b>	<b>140+ 1S DCH (40+100)</b>	<b>140 2S (60+20+60)</b>			○
	Ref. 126757	Ref. 126758	Ref. 126273			○
	<b>160+ 1S IZD (80+80)</b>	<b>160+ 1S DCH (80+80)</b>	<b>160 2S (60+40+60)</b>	<b>160 2S (80+80)</b>		○
	Ref. 126759	Ref. 126760	Ref. 126274	Ref. 126761		○
	<b>180 2S (60+60+60)</b>	<b>200 2S (80+40+80)</b>	<b>200+ 2S (100+100)</b>			○
	Ref. 126275	Ref. 126276	Ref. 126762			○

ES\_Códigos sombreados en stock.  
 EN\_Shaded codes are in stock.  
 FR\_Les codes surlignés sont en stock.  
 IT\_I codici ombreggiati sono in stock.

**SKY\_CONSOLA CON LAVABO INTEGRADO MINERAL COVER** NEW

Console with built-in washbasin / Console vasques intégrées/ Console con lavabo integrato

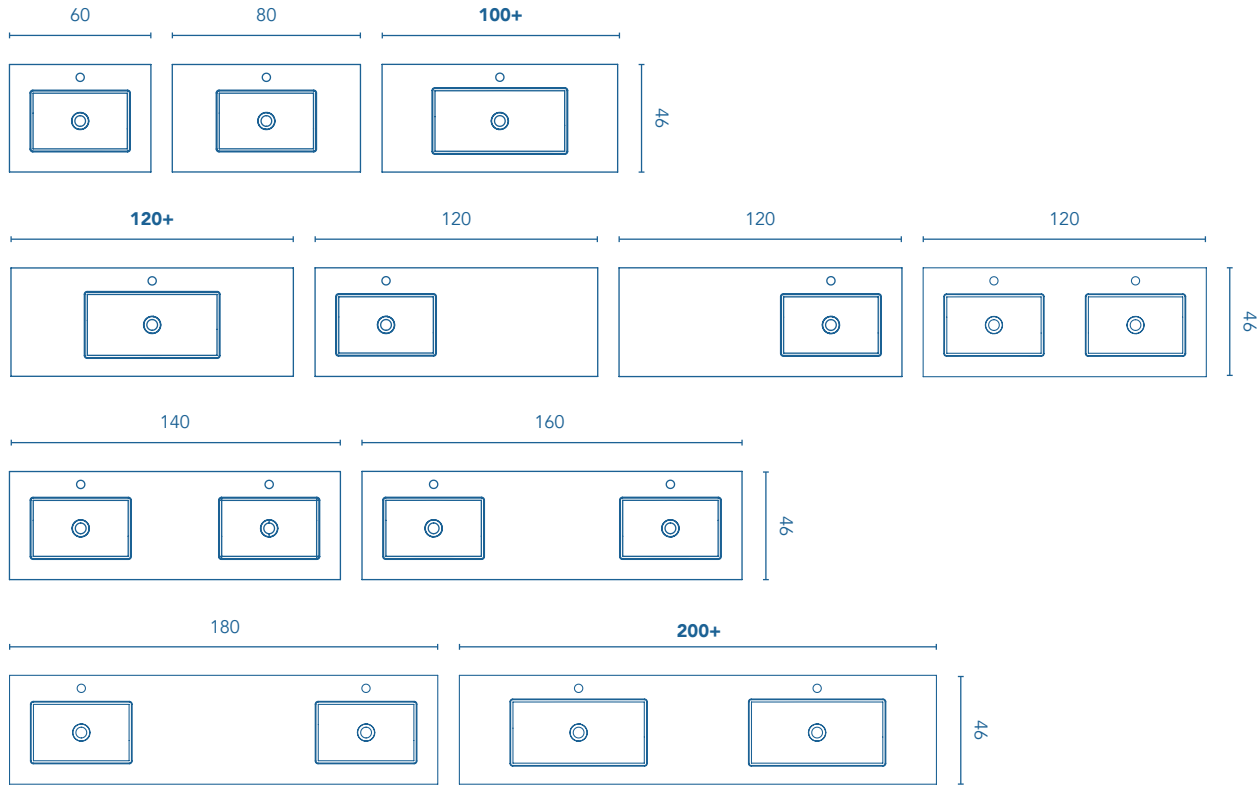

Acabado mate/ Matt finish/ Finition mat/ Finitura opaca.  
 Profundidad del seno 12/ Sink depth 12/ Profondeur du bac 12/ Profondità della vasca 12.  
 Altura 10/ Height 10/ Hauteur 10/ Altezza 10.



SKY	60	80	100+	120+	120 1S IZD	120 1S DCH	120 2S	
	Ref. 126277	Ref. 126278	Ref. 126279	Ref. 126280	Ref. 126281	Ref. 126282	Ref. 126283	<input type="radio"/>
	<b>140</b>	<b>160</b>	<b>180</b>	<b>200+</b>				<input type="radio"/>
	Ref. 126284	Ref. 126285	Ref. 126286	Ref. 126287				

**ESCUADRA**

Bracket/ Équerre/ Staffe

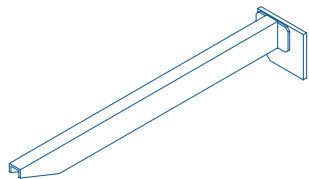

1 unidad/ 1 unit/ 1 unité/ 1 unità.

40 x 1,7 x 3,5

Ref. 126899



Tamaño seno/ Sink size/ Taille du bac/ Dimensione della vasca.

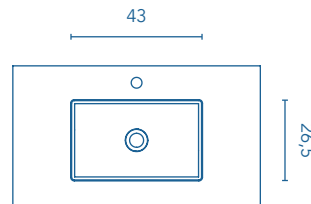

Tamaño seno +/ Sink size +/ Taille du bac +/ Dimensione della vasca +.

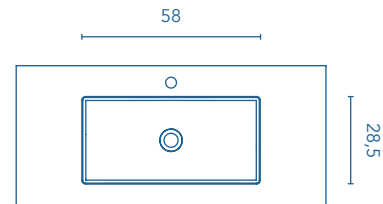

ES\_Escuadra para consola con lavabo integrado Sky. Para medidas de hasta 120: 2 escuadras; de 140 a 180: 3 escuadras; para 200: 4 escuadras.

EN\_Bracket for Sky console with built-in washbasin. For sizes up to 120: 2 brackets; from 140 to 180: 3 brackets; for 200: 4 brackets.

FR\_Équerre pour console vasques intégrées Sky. Pour dimensions allant jusqu'à 120: 2 équerres ; de 140 à 180: 3 équerres; pour 200: 4 équerres.

IT\_Staffe per consola con lavabo integrato Sky. Per misure fino a 120: 2 staffe; da 140 a 180: 3 staffe; per 200: 4 staffe.

## LAVABOS CERÁMICOS SOBRE ENCIMERA

Ceramic countertop washbasins/ Plans vasques céramique à poser sur plan/ Lavabi in ceramica per tops

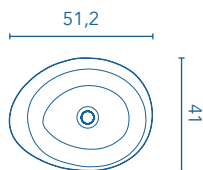

Profundidad del seno 14/ Sink depth 14/ Profondeur du bac 14/ Profondità della vasca 14

Acabado brillo/ Gloss finish  
Finition brillance/ Finitura lucida

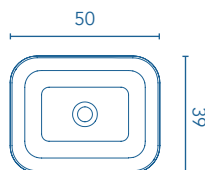

Profundidad del seno 13/ Sink depth 13/ Profondeur du bac 13/ Profondità della vasca 13

Acabado brillo/ Gloss finish  
Finition brillance/ Finitura lucida

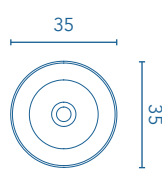

Profundidad del seno 12,5/ Sink depth 12,5/ Profondeur du bac 12,5/ Profondità della vasca 12,5

Acabado brillo/ Gloss finish  
Finition brillance/ Finitura lucida

**GALAXY**   
Ref. 116985 

**NOMIA**   
Ref. 125818 

**NYSA**   
Ref. 125816 

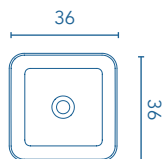

Profundidad del seno 12,5/ Sink depth 12,5/ Profondeur du bac 12,5/ Profondità della vasca 12,5

Acabado brillo/ Gloss finish  
Finition brillance/ Finitura lucida

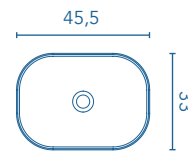

Profundidad del seno 13,5/ Sink depth 13,5/ Profondeur du bac 13,5/ Profondità della vasca 13,5

Acabado mate/ Matt finish  
Finition mat/ Finitura opaca

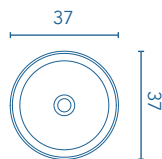

Profundidad del seno 12/ Sink depth 12/ Profondeur du bac 12/ Profondità della vasca 12

Acabado mate/ Matt finish  
Finition mat/ Finitura opaca

**ZALA**   
Ref. 125817 

**BLOCK**    
Ref. 126289 

**SUN**    
Ref. 126288 

## LAVABOS MINERAL COVER SOBRE ENCIMERA

Mineral cover countertop washbasins/ Plans vasques mineral cover à poser sur plan/ Lavabi mineral cover per tops

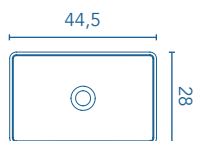

Profundidad del seno 12/ Sink depth 12/ Profondeur du bac 12/ Profondità della vasca 12

Acabado mate/ Matt finish  
Finition mat/ Finitura opaca

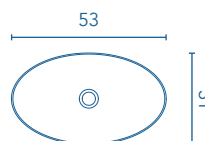

Profundidad del seno 11,5/ Sink depth 11,5/ Profondeur du bac 11,5/ Profondità della vasca 11,5

Acabado mate/ Matt finish  
Finition mat/ Finitura opaca

**TAOS**    
Ref. 126290 

**VOLTA**    
Ref. 126724 

ES\_Códigos sombreados en stock.  
EN\_Shaded codes are in stock.  
FR\_Les codes surlignés sont en stock.  
IT\_I codici ombreggiati sono in stock.

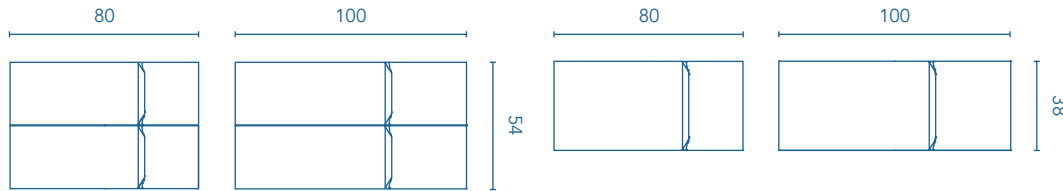
**MUEBLE****Furniture/ Meuble/ Mobile**

Profundidad 48-52/ Depth 48-52/ Profondeur 48-52/ Profondità 48-52.



80 2C	100 2C	80 1C	100 1C
Ref. 126474	Ref. 126478	Ref. 126466	Ref. 126470
Ref. 126475	Ref. 126479	Ref. 126467	Ref. 126471
Ref. 126476	Ref. 126480	Ref. 126468	Ref. 126472
Ref. 126477	Ref. 126481	Ref. 126469	Ref. 126473

Acabados/ Finishes/  
Finitions/ Finiture

- BL19
- RO6
- MA15M
- BL20M

ES\_Para mueble de 1 cajón se incluye 1 cajita organizadora, para mueble de 2 cajones se incluyen 2 cajitas organizadoras.  
 EN\_For single-drawer cabinets, 1 organiser box is included, for two-drawer cabinets, 2 organiser boxes are included.  
 FR\_Pour meuble de 1 tiroir, 1 bac de rangement est inclu, pour meuble de 2 tiroirs 2 bacs de rangement son inclus.  
 IT\_Per i mobili con 1 cassetto è inclusa una scatola organizer, mentre per i mobili con 2 cassetti sono comprese 2 scatole organizer.

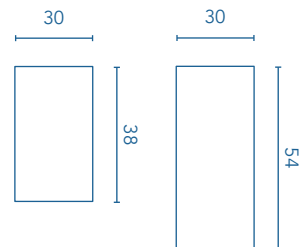
**BAJO****Base unit/ Meuble bas/ Mobile basso**

Profundidad 43/ Depth 43/ Profondeur 43/ Profondità 43.



1P DCH (H.38)	1P IZD (H.38)	1P DCH (H.54)	1P IZD (H.54)
Ref. 126482	Ref. 126486	Ref. 126490	Ref. 126494
Ref. 126483	Ref. 126487	Ref. 126491	Ref. 126495
Ref. 126484	Ref. 126488	Ref. 126492	Ref. 126496
Ref. 126485	Ref. 126489	Ref. 126493	Ref. 126497

Acabados/ Finishes/  
Finitions/ Finiture

- BL19
- RO6
- MA15M
- BL20M

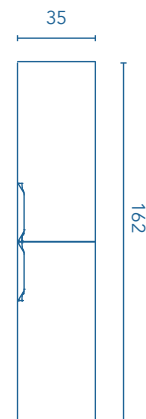
**COLUMNNA****Column/ Colonne/ Colonna**Profundidad 24/ Depth 24/  
Profondeur 24/ Profondità 24.**2P**

Ref. 126498
Ref. 126499
Ref. 126500
Ref. 126501

Acabados/ Finishes/  
Finitions/ Finiture

- BL19
- RO6
- MA15M
- BL20M

ES\_Códigos sombreados en stock.  
 EN\_Shaded codes are in stock.  
 FR\_Les codes surlignés sont en stock.  
 IT\_I codici ombreggiati sono in stock.

ES\_Interior: 4 estantes móviles de cristal y 1 estante fijo de madera.  
 EN\_Interior: 4 mobile glass shelves and 1 fixed wooden shelf.  
 FR\_Intérieur: 4 étagères amovibles en verre et 1 étagère fixe en bois.  
 IT\_Interno: 4 mensole rimovibili di vetro e 1 mensola fissa in legno.

## ENCIMERAS

Worktops/ Plans/ Tops per lavabo

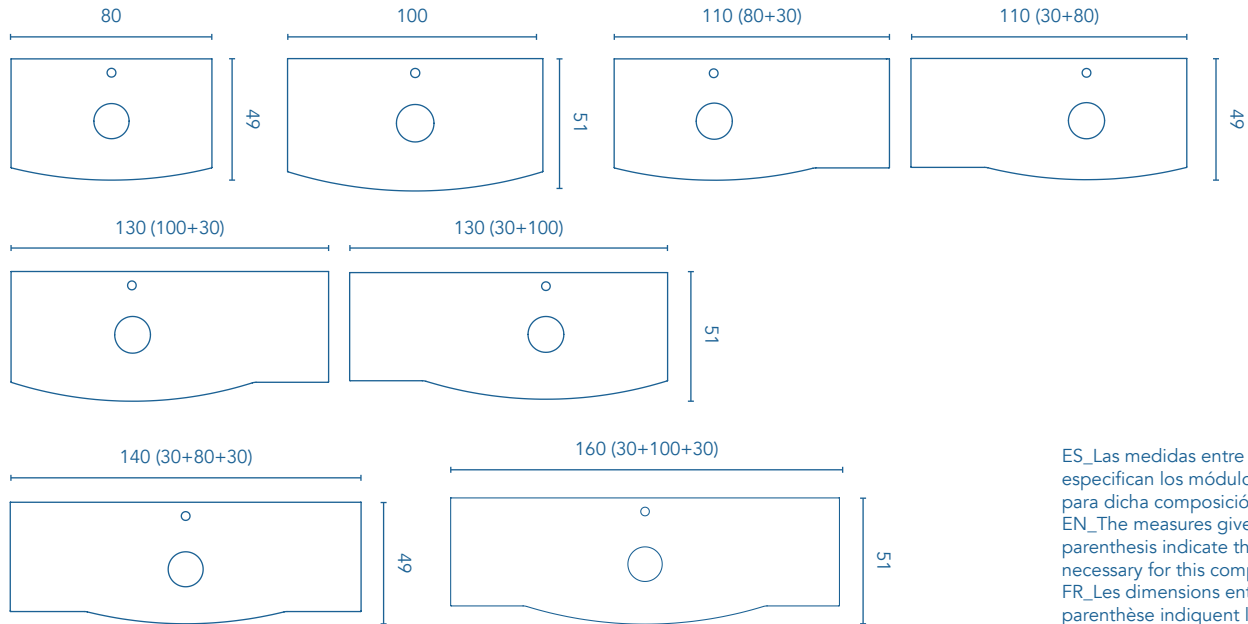

3D - Espesor 1,8/ Thickness 1,8/ Épaisseur 1,8/ Spessore 1,8.  
 Mineral cover - Espesor 1,2/ Thickness 1,2/ Épaisseur 1,2/ Spessore 1,2.  
 Marble stone - Espesor 2/ Thickness 2/ Épaisseur 2/ Spessore 2.

ES\_Las medidas entre paréntesis especifican los módulos necesarios para dicha composición.  
 EN\_The measures given in parenthesis indicate the units necessary for this composition.  
 FR\_Les dimensions entre parenthèse indiquent les modules nécessaires pour la composition.  
 IT\_Le misure in parentesi specificano i moduli necessari per l'utilizzo del lavabo relativo.

80	100	110 IZD	110 DCH	130 IZD	130 DCH	140	160	Acabados/ Finishes/ Finitions/ Finiture
Ref. 126502	Ref. 126506	Ref. 126510	Ref. 126514	Ref. 126518	Ref. 126522	Ref. 126526	Ref. 126530	BL19
Ref. 126503	Ref. 126507	Ref. 126511	Ref. 126515	Ref. 126519	Ref. 126523	Ref. 126527	Ref. 126531	RO6
Ref. 126504	Ref. 126508	Ref. 126512	Ref. 126516	Ref. 126520	Ref. 126524	Ref. 126528	Ref. 126532	MA15M
Ref. 126505	Ref. 126509	Ref. 126513	Ref. 126517	Ref. 126521	Ref. 126525	Ref. 126529	Ref. 126533	BL20M
Ref. 126534	Ref. 126537	Ref. 126540	Ref. 126543	Ref. 126546	Ref. 126549	Ref. 126552	Ref. 126555	Mineral cover
Ref. 126535	Ref. 126538	Ref. 126541	Ref. 126544	Ref. 126547	Ref. 126550	Ref. 126553	Ref. 126556	Marble stone

## ACABADOS

Finishes/ Finitions/ Finiture



BL19: Blanco nature/  
Nature white/ Blanc  
nature/ Bianco nature



RO6: Beige nature/  
Nature beige/ Beige  
nature/ Beige nature



MA15M: Arena mate/  
Sand matt finish/ Sable  
mat/ Sabbia matte

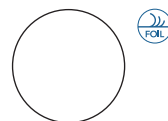

BL20M: Blanco mate/  
Matt white/ Blanc mat/  
Bianco opaco

### TREND\_LAVABO INTEGRADO CERÁMICO

Built-in ceramic washbasin/ Plan vasque intégrée céramique/ Lavabo integrato in ceramica

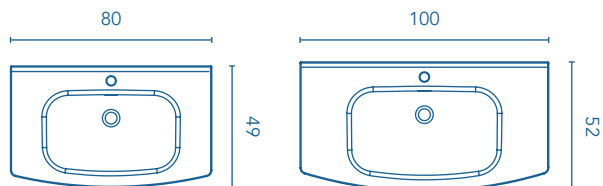

Acabado brillo/ Gloss finish/ Finition brillante/ Finitura lucida.  
 Profundidad del seno 15/ Sink depth 15/ Profondeur du bac 15/ Profondità della vasca 15.  
 Espesor 2/ Thickness 2/ Épaisseur 2/ Spessore 2.



TREND	80	100
	Ref. 123067	Ref. 123068

### GLOOB\_ENCIMERA CON LAVABO INTEGRADO MINERAL COVER NEW

Mineral cover worktop with built-in washbasin/ Plan vasque intégrée mineral cover/ Top lavabo integrato mineral cover

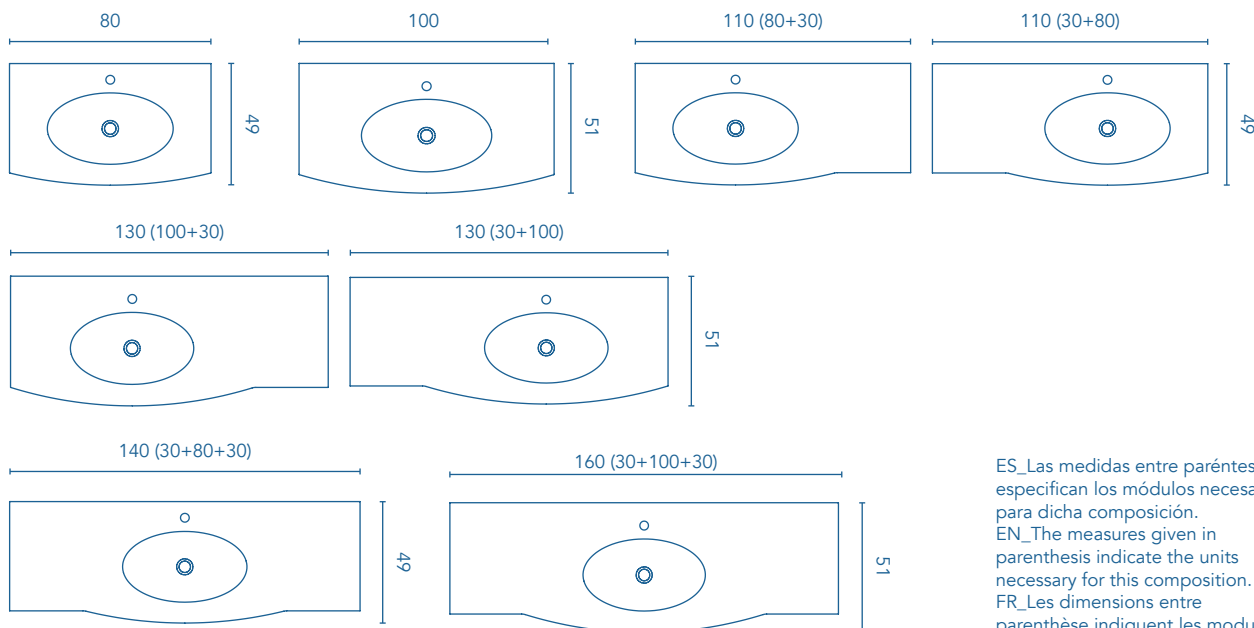

Acabado mate/ Matt finish/ Finition mat/ Finitura opaca.  
 Profundidad del seno 12/ Sink depth 12/ Profondeur du bac 12/ Profondità della vasca 12.  
 Espesor 1,2/ Thickness 1,2/ Épaisseur 1,2/ Spessore 1,2.

ES\_Las medidas entre paréntesis especifican los módulos necesarios para dicha composición.  
 EN\_The measures given in parenthesis indicate the units necessary for this composition.  
 FR\_Les dimensions entre parenthèse indiquent les modules nécessaires pour la composition.  
 IT\_Le misure in parentesi specificano i moduli necessari per l'utilizzo del lavabo relativo.



GLOOB	80	100	110 IZD	110 DCH	130 IZD	130 DCH	140	160
	Ref. 126340	Ref. 126341	Ref. 126342	Ref. 126343	Ref. 126344	Ref. 126345	Ref. 126346	Ref. 126347

## LAVABOS CERÁMICOS SOBRE ENCIMERA

Ceramic countertop washbasins/ Plans vasques céramique à poser sur plan/ Lavabi in ceramica per tops

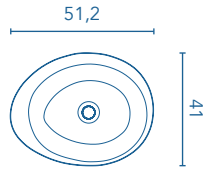

Profundidad del seno 14/ Sink depth 14/ Profondeur du bac 14/ Profondità della vasca 14

Acabado brillo/ Gloss finish  
Finition brillance/ Finitura lucida

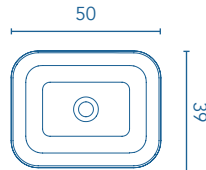

Profundidad del seno 13/ Sink depth 13/ Profondeur du bac 13/ Profondità della vasca 13

Acabado brillo/ Gloss finish  
Finition brillance/ Finitura lucida

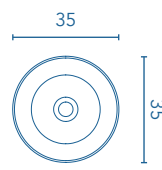

Profundidad del seno 12,5/ Sink depth 12,5/ Profondeur du bac 12,5/ Profondità della vasca 12,5

Acabado brillo/ Gloss finish  
Finition brillance/ Finitura lucida

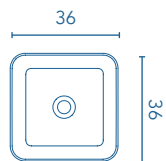

Profundidad del seno 12,5/ Sink depth 12,5/ Profondeur du bac 12,5/ Profondità della vasca 12,5

Acabado brillo/ Gloss finish  
Finition brillance/ Finitura lucida

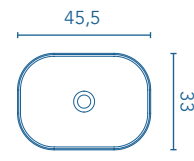

Profundidad del seno 13,5/ Sink depth 13,5/ Profondeur du bac 13,5/ Profondità della vasca 13,5

Acabado mate/ Matt finish  
Finition mat/ Finitura opaca

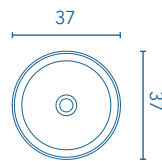

Profundidad del seno 12/ Sink depth 12/ Profondeur du bac 12/ Profondità della vasca 12

Acabado mate/ Matt finish  
Finition mat/ Finitura opaca

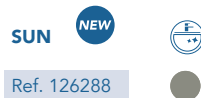
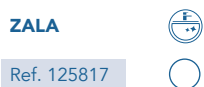

## LAVABOS MINERAL COVER SOBRE ENCIMERA

Mineral cover countertop washbasins/ Plans vasques mineral cover à poser sur plan/ Lavabi mineral cover per tops

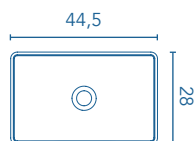

Profundidad del seno 12/ Sink depth 12/ Profondeur du bac 12/ Profondità della vasca 12

Acabado mate/ Matt finish  
Finition mat/ Finitura opaca

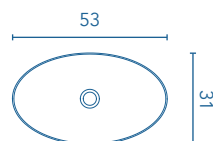

Profundidad del seno 11,5/ Sink depth 11,5/ Profondeur du bac 11,5/ Profondità della vasca 11,5

Acabado mate/ Matt finish  
Finition mat/ Finitura opaca

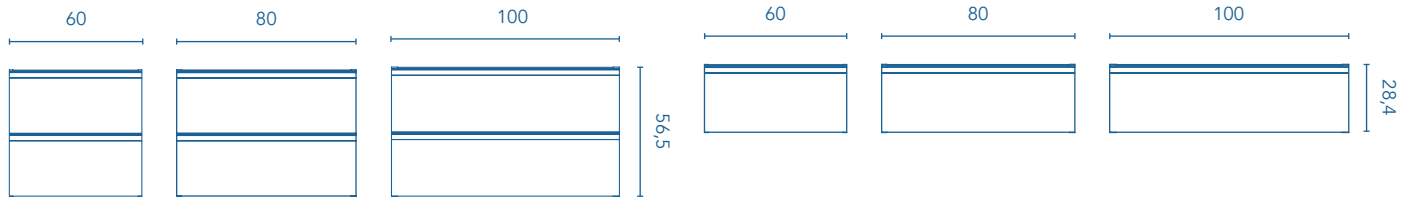

ES\_Códigos sombreados en stock.  
EN\_Shaded codes are in stock.  
FR\_Les codes surlignés sont en stock.  
IT\_I codici ombreggiati sono in stock.

**MUEBLE****Furniture/ Meuble/ Mobile**

Profundidad 45/ Depth 45/ Profondeur 45/ Profondità 45.



60 2C	80 2C	100 2C	60 1C	80 1C	100 1C	Acabados/ Finishes/ Finitions/ Finiture
Ref. 126641	Ref. 126645	Ref. 126649	Ref. 126629	Ref. 126633	Ref. 126637	GR21
Ref. 126642	Ref. 126646	Ref. 126650	Ref. 126630	Ref. 126634	Ref. 126638	NO14
Ref. 126639	Ref. 126643	Ref. 126647	Ref. 126627	Ref. 126631	Ref. 126635	BL1B
Ref. 126640	Ref. 126644	Ref. 126648	Ref. 126628	Ref. 126632	Ref. 126636	GR16B

ES\_Mueble con salva sifón y organizador de cajón. Mueble sin tirador.

Necesario customizarlo con un tirador en cada cajón.

EN\_Unit with drain protection and drawer organizer. Unit without handle.

It must be customized with a handle for each drawer.

FR\_Meuble avec découpe siphon et organisateur de tiroir. Meuble sans

poignée. Il est nécessaire de le personnaliser avec une poignée pour

chaque tiroir.

IT\_Mobile con salva sifone e organizer da cassetto. Mobile senza maniglia.

È necessario personalizzarlo con una maniglia per ogni cassetto.

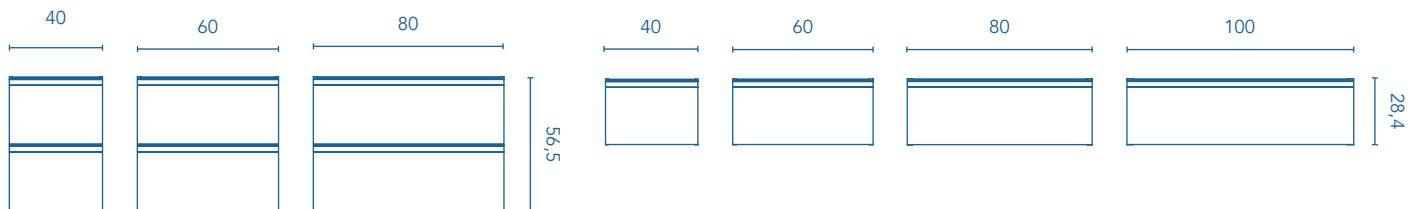
**BAJO****Base unit/ Meuble bas/ Mobile basso**

Profundidad 45/ Depth 45/ Profondeur 45/ Profondità 45.



40 2C	60 2C	80 2C	40 1C	60 1C	80 1C	100 1C	Acabados/ Finishes/ Finitions/ Finiture
Ref. 126669	Ref. 126673	Ref. 126677	Ref. 126653	Ref. 126657	Ref. 126661	Ref. 126665	GR21
Ref. 126670	Ref. 126674	Ref. 126678	Ref. 126654	Ref. 126658	Ref. 126662	Ref. 126666	NO14
Ref. 126667	Ref. 126671	Ref. 126675	Ref. 126651	Ref. 126655	Ref. 126659	Ref. 126663	BL1B
Ref. 126668	Ref. 126672	Ref. 126676	Ref. 126652	Ref. 126656	Ref. 126660	Ref. 126664	GR16B

ES\_Mueble auxiliar, sin salva sifón ni organizador de cajón. Mueble

sin tirador. Necesario customizarlo con un tirador en cada cajón.

EN\_Auxiliary unit, without drain protection and drawer organizer.

Unit without handle. It must be customized with a handle for each drawer.

FR\_Meuble auxiliaire, sans découpe siphon et organisateur de tiroir. Meuble

sans poignée. Il est nécessaire de le personnaliser avec une poignée pour

chaque tiroir.

IT\_Mobile ausiliario, senza salva sifone e organizer da cassetto. Mobile senza

maniglia. È necessario personalizzarlo con una maniglia per ogni cassetto.

ES\_Códigos sombreados en stock.  
 EN\_Shaded codes are in stock.  
 FR\_Les codes surlignés sont en stock.  
 IT\_I codici ombreggiati sono in stock.



## MÓDULO ABIERTO

Open module/ Module ouvert/ Modulo aperto

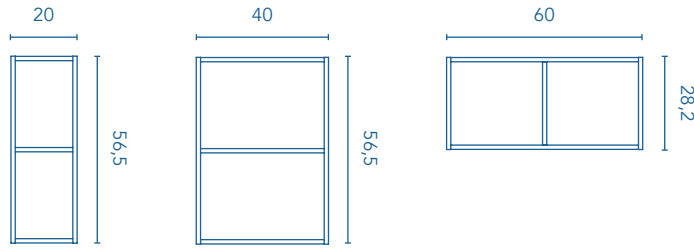

Profundidad 45/ Depth 45/ Profondeur 45/ Profondità 45.

20	40	60	Acabados/ Finishes/ Finitions/ Finiture
Ref. 126681	Ref. 126685	Ref. 126689	● GR21
Ref. 126682	Ref. 126686	Ref. 126690	● NO14
Ref. 126679	Ref. 126683	Ref. 126687	○ BL1B
Ref. 126680	Ref. 126684	Ref. 126688	● GR16B

## TIRADOR

Handle/ Poignée/ Maniglia

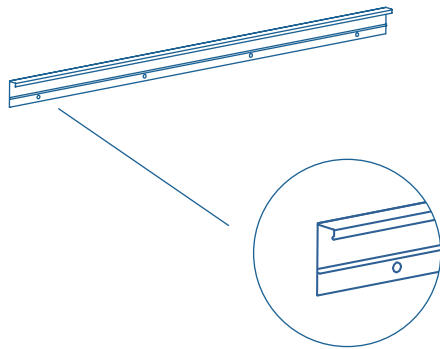

ES\_Elige tu tirador entre los diferentes acabados. Necesario customizarlo con un tirador en cada cajón.  
EN\_Choose your handle from the different finishes available. It must be customized with a handle for each drawer.  
FR\_Choisissez votre poignée parmi les différentes finitions. Il est nécessaire de le personnaliser avec une poignée pour chaque tiroir.  
IT\_Scegli la maniglia tra diverse finiture. È necessario personalizzarlo con una maniglia per ogni cassetto.

1 unidad/ 1 unit/ 1 unité/ 1 unità.

40	60	80	100	Acabados/ Finishes/ Finitions/ Finiture
Ref. 126742	Ref. 126745	Ref. 126748	Ref. 126751	● Cromo/ Chrome/ Chromée/ Cromo
Ref. 126743	Ref. 126746	Ref. 126749	Ref. 126752	● Negro/ Black/ Noir/ Nero
Ref. 126741	Ref. 126744	Ref. 126747	Ref. 126750	○ Blanco/ White/ Blanc/ Bianco

## COLUMNA

Column/ Colonne/ Colonna



Profundidad 24/ Depth 24/  
Profondeur 24/ Profondità 24.



2P	Acabados/ Finishes/ Finitions/ Finiture
Ref. 124847	● GR21
Ref. 124848	● NO14
Ref. 124845	○ BL1B
Ref. 124846	● GR16B

ES\_Interior: 2 estantes móviles de madera y 1 estante fijo de madera.  
EN\_Interior: 2 mobile wooden shelves and 1 fixed wooden shelf.  
FR\_Intérieur: 2 étagères amovibles en bois et 1 étagère fixe en bois.  
IT\_Interno: 2 mensole rimovibili in legno e 1 mensola fissa in legno.

## ACABADOS

Finishes/ Finitions/ Finiture

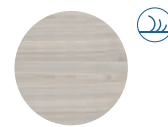

GR21: Gris arenado/  
Sandy grey/ Gris sablé/  
Grigio sabbiato



NO14: Nogal arenado/  
Sandy walnut/ Coloris  
noyer sablé/ Noce sabbiato

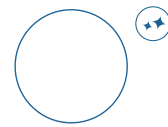

BL1B: Blanco/ White/  
Blanc/ Bianco

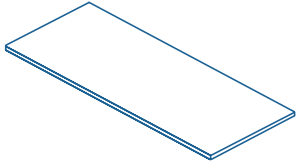

GR16B: Antracita/  
Anthracite/ Anthracite/  
Antracite

**TAPAS****Tops/ Couvercle/ Tops**

Profundidad 46/ Depth 46/ Profondeur 46/ Profondità 46.  
 Espesor melamina 1,6/ Melamine thickness 1,6/ Épaisseur du mélamine 1,6/ Spessore melamina 1,6.  
 Espesor lacado 1,9/ Lacquered thickness 1,9/ Épaisseur du laqué 1,9/ Spessore laccato 1,9.

40	60	80	100	120	140	160	180	200	Acabados/ Finishes/ Finitions/ Finiture
Ref. 126593	Ref. 126597	Ref. 126601	Ref. 126605	Ref. 126609	Ref. 126613	Ref. 126617	Ref. 126621	Ref. 126625	GR21
Ref. 126594	Ref. 126598	Ref. 126602	Ref. 126606	Ref. 126610	Ref. 126614	Ref. 126618	Ref. 126622	Ref. 126626	NO14
Ref. 126591	Ref. 126595	Ref. 126599	Ref. 126603	Ref. 126607	Ref. 126611	Ref. 126615	Ref. 126619	Ref. 126623	BL1B
Ref. 126592	Ref. 126596	Ref. 126600	Ref. 126604	Ref. 126608	Ref. 126612	Ref. 126616	Ref. 126620	Ref. 126624	GR16B

ES\_No admite lavabo.  
 EN\_Doesn't admit washbasin.  
 FR\_N'accepte pas de plan vasque.  
 IT\_Non prevede lavabo.

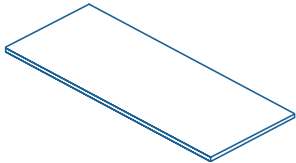
**ENCIMERAS****Worktops/ Plans/ Tops per lavabo**

Profundidad 46/ Depth 46/ Profondeur 46/ Profondità 46.  
 Espesor melamina 1,6/ Melamine thickness 1,6/ Épaisseur du mélamine 1,6/ Spessore melamina 1,6.  
 Espesor lacado 1,9/ Lacquered thickness 1,9/ Épaisseur du laqué 1,9/ Spessore laccato 1,9.  
 Mineral cover - Espesor 1,2/ Thickness 1,2/ Épaisseur 1,2/ Spessore 1,2.  
 Marble stone - Espesor 2/ Thickness 2/ Épaisseur 2/ Spessore 2.  
 Concretech - Espesor 1,5/ Thickness 1,5/ Épaisseur 1,5/ Spessore 1,5.

60	80	100	120	140	160	180	200	Acabados/ Finishes/ Finitions/ Finiture
Ref. 126597	Ref. 126601	Ref. 126605	Ref. 126609	Ref. 126613	Ref. 126617	Ref. 126621	Ref. 126625	GR21
Ref. 126598	Ref. 126602	Ref. 126606	Ref. 126610	Ref. 126614	Ref. 126618	Ref. 126622	Ref. 126626	NO14
Ref. 126595	Ref. 126599	Ref. 126603	Ref. 126607	Ref. 126611	Ref. 126615	Ref. 126619	Ref. 126623	BL1B
Ref. 126596	Ref. 126600	Ref. 126604	Ref. 126608	Ref. 126612	Ref. 126616	Ref. 126620	Ref. 126624	GR16B
Ref. 126291	Ref. 126292	Ref. 126293	Ref. 126294	Ref. 126295	Ref. 126296	Ref. 126297	Ref. 126298	Mineral cover
Ref. 126307	Ref. 126308	Ref. 126309	Ref. 126310	Ref. 126311	Ref. 126312	Ref. 126313	Ref. 126314	Marble stone
Ref. 126299	Ref. 126300	Ref. 126301	Ref. 126302	Ref. 126303	Ref. 126304	Ref. 126305	Ref. 126306	Concretech

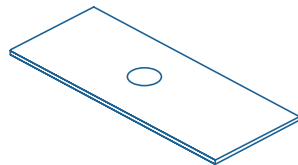
**ENCIMERA MECANIZADA****Machined worktop/ Plans avec découpe/ Top meccanizzato**

Profundidad 46/ Depth 46/ Profondeur 46/ Profondità 46.

Espesor melamina 1,6/ Melamine thickness 1,6/ Épaisseur du mélamine 1,6/ Spessore melamina 1,6.

Espesor lacado 1,9/ Lacquered thickness 1,9/ Épaisseur du laqué 1,9/ Spessore laccato 1,9.

60	80	100
Ref. 126581	Ref. 126585	Ref. 126589
Ref. 126582	Ref. 126586	Ref. 126590
Ref. 126579	Ref. 126583	Ref. 126587
Ref. 126580	Ref. 126584	Ref. 126588

Acabados/ Finishes/  
Finitions/ Finiture

ES\_Encimeras válidas únicamente para módulos de 60, 80 y 100 con seno central.

EN\_Worktops valid only for 60, 80 and 100cm modules with central basin.

FR\_Jupes compatibles uniquement avec les modules de 60, 80 et 100 avec vasque centrale.

IT\_Top validi unicamente per moduli da 60, 80 e 100 con lavabo centrale.

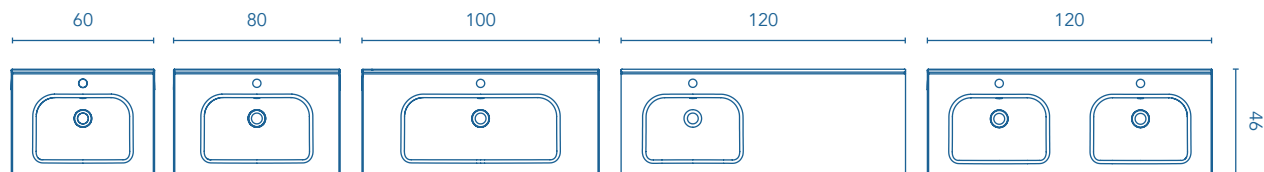
**SLIM\_LAVABO INTEGRADO CERÁMICO****Built-in ceramic washbasin/ Plan vasque intégrée céramique/ Lavabo integrato in ceramica**

Acabado brillo/ Gloss finish/ Finition brillante/ Finitura lucida.

Profundidad del seno 12,5/ Sink depth 12,5/ Profondeur du bac 12,5/ Profondità della vasca 12,5.

Espesor 2/ Thickness 2/ Épaisseur 2/ Spessore 2.



SLIM	60	80	100	120 1S IZD	120 2S
	Ref. 123341	Ref. 123343	Ref. 123344	Ref. 125316	Ref. 123345



ES\_Códigos sombreados en stock.  
EN\_Shaded codes are in stock.  
FR\_Les codes surlignés sont en stock.  
IT\_I codici ombreggiati sono in stock.

## SKY\_ENCIMERA CON LAVABO INTEGRADO MINERAL COVER NEW

Worktop with built-in mineral cover washbasin/ Plan vasque intégrée mineral cover/ Top lavabo integrato mineral cover

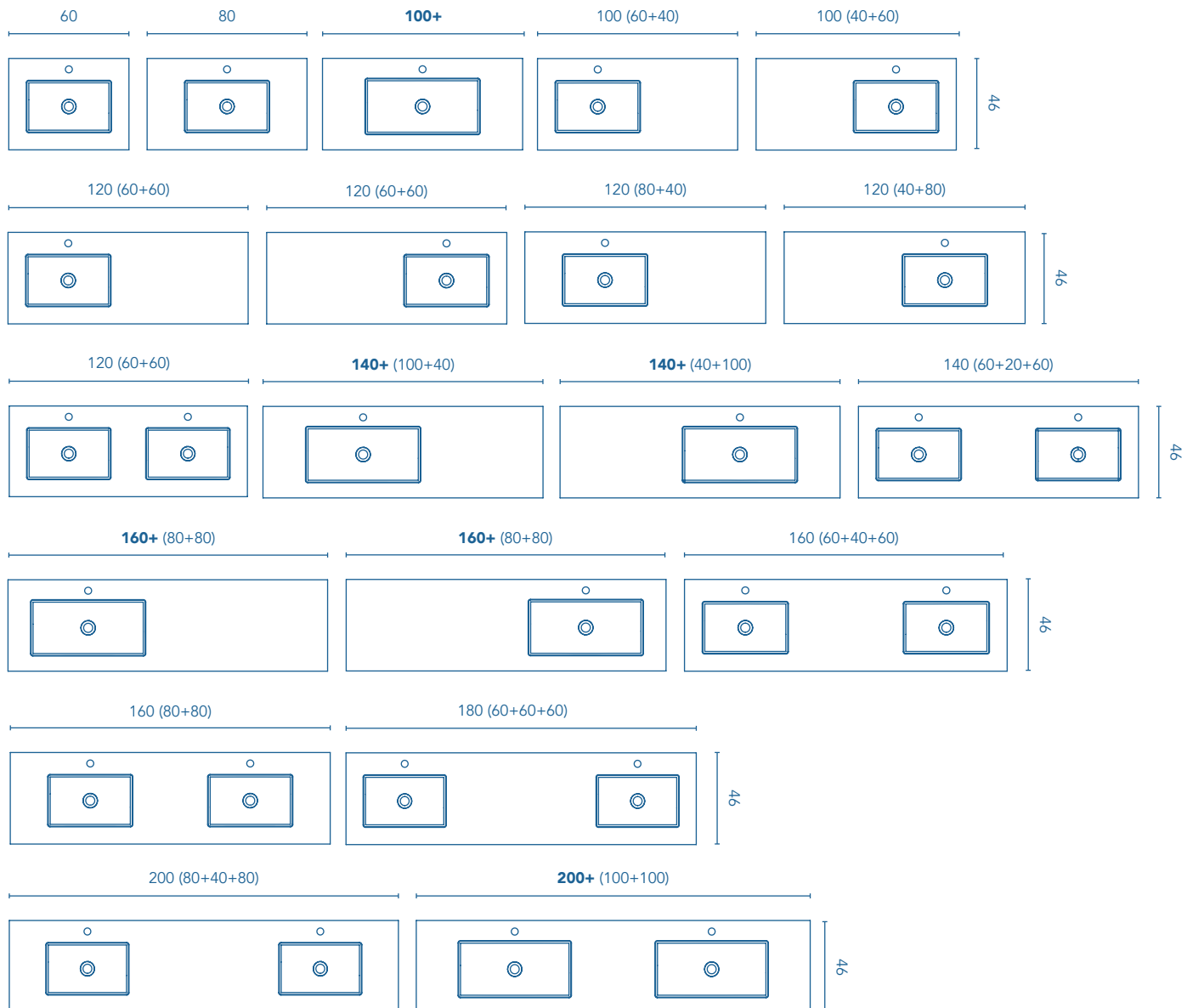

ES\_Las medidas entre paréntesis especifican los módulos necesarios para dicha composición.

EN\_The measures given in parenthesis indicate the units necessary for this composition.

FR\_Les dimensions entre parenthèse indiquent les modules nécessaires pour la composition.

IT\_Le misure in parentesi specificano i moduli necessari per l'utilizzo del lavabo relativo.

Tamaño seno/ Sink size/ Taille du bac/ Dimensione della vasca.

Tamaño seno +/- Sink size +/- Taille du bac +/- Dimensione della vasca +.

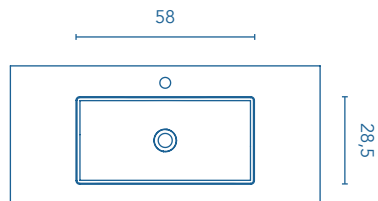
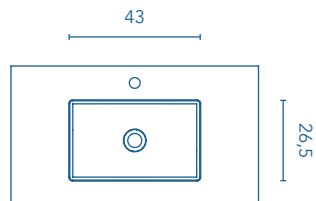

Acabado mate/ Matt finish/ Finition mat/ Finitura opaca.  
 Profundidad del seno 12/ Sink depth 12/ Profondeur du bac 12/ Profondità della vasca 12.  
 Espesor 1,2/ Thickness 1,2/ Épaisseur 1,2/ Spessore 1,2.



SKY	60	80	100+	100 1S IZD (60+40)	100 1S DCH (40+60)	
	Ref. 126267	Ref. 126268	Ref. 126269	Ref. 126753	Ref. 126754	○
	<b>120 1S IZD (60+60)</b>	<b>120 1S DCH (60+60)</b>	<b>120 1S IZD (80+40)</b>	<b>120 1S DCH (40+80)</b>	<b>120 2S (60+60)</b>	○
	Ref. 126270	Ref. 126271	Ref. 126755	Ref. 126756	Ref. 126272	○
	<b>140+ 1S IZD (100+40)</b>	<b>140+ 1S DCH (40+100)</b>	<b>140 2S (60+20+60)</b>			○
	Ref. 126757	Ref. 126758	Ref. 126273			○
	<b>160+ 1S IZD (80+80)</b>	<b>160+ 1S DCH (80+80)</b>	<b>160 2S (60+40+60)</b>	<b>160 2S (80+80)</b>		○
	Ref. 126759	Ref. 126760	Ref. 126274	Ref. 126761		○
	<b>180 2S (60+60+60)</b>	<b>200 2S (80+40+80)</b>	<b>200+ 2S (100+100)</b>			○
	Ref. 126275	Ref. 126276	Ref. 126762			○

ES\_Códigos sombreados en stock.  
 EN\_Shaded codes are in stock.  
 FR\_Les codes surlignés sont en stock.  
 IT\_I codici ombreggiati sono in stock.

**SKY\_CONSOLA CON LAVABO INTEGRADO MINERAL COVER** NEW

Console with built-in washbasin / Console vasques intégrées/ Console con lavabo integrato

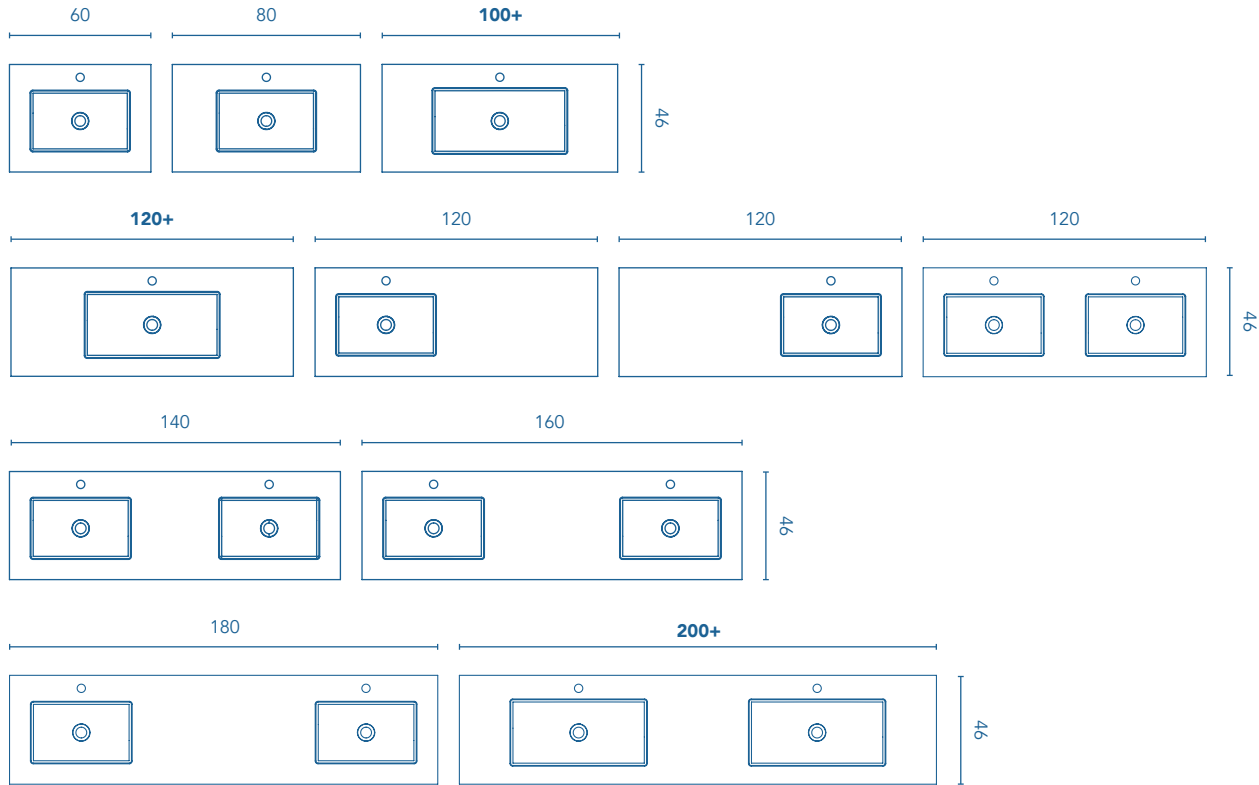

Acabado mate/ Matt finish/ Finition mat/ Finitura opaca.  
 Profundidad del seno 12/ Sink depth 12/ Profondeur du bac 12/ Profondità della vasca 12.  
 Altura 10/ Height 10/ Hauteur 10/ Altezza 10.



SKY	60	80	100+	120+	120 1S IZD	120 1S DCH	120 2S	
	Ref. 126277	Ref. 126278	Ref. 126279	Ref. 126280	Ref. 126281	Ref. 126282	Ref. 126283	
	<b>140</b>	<b>160</b>	<b>180</b>	<b>200+</b>				
	Ref. 126284	Ref. 126285	Ref. 126286	Ref. 126287				

**ESCUADRA**

Bracket/ Équerre/ Staffe

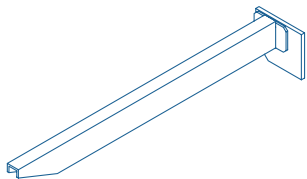

1 unidad/ 1 unit/ 1 unité/ 1 unità.

40 x 1,7 x 3,5

Ref. 126899



Tamaño seno/ Sink size/ Taille du bac/ Dimensione della vasca.

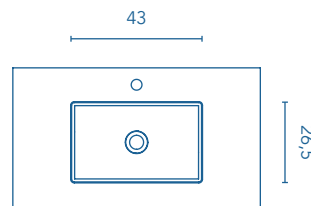

Tamaño seno +/ Sink size +/ Taille du bac +/ Dimensione della vasca +.

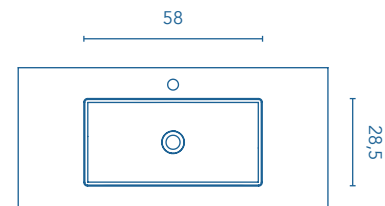

ES\_Escuadra para consola con lavabo integrado Sky. Para medidas de hasta 120: 2 escuadras; de 140 a 180: 3 escuadras; para 200: 4 escuadras.

EN\_Bracket for Sky console with built-in washbasin. For sizes up to 120: 2 brackets; from 140 to 180: 3 brackets; for 200: 4 brackets.

FR\_Équerre pour console vasques intégrées Sky. Pour dimensions allant jusqu'à 120: 2 équerres ; de 140 à 180: 3 équerres; pour 200: 4 équerres.

IT\_Staffa per consola con lavabo integrato Sky. Per misure fino a 120: 2 staffe; da 140 a 180: 3 staffe; per 200: 4 staffe.

## LAVABOS CERÁMICOS SOBRE ENCIMERA

Ceramic countertop washbasins/ Plans vasques céramique à poser sur plan/ Lavabi in ceramica per tops

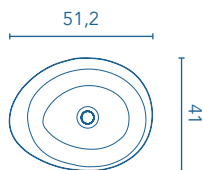

Profundidad del seno 14/ Sink depth 14/ Profondeur du bac 14/ Profondità della vasca 14

Acabado brillo/ Gloss finish  
Finition brillance/ Finitura lucida

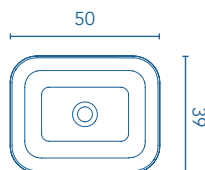

Profundidad del seno 13/ Sink depth 13/ Profondeur du bac 13/ Profondità della vasca 13

Acabado brillo/ Gloss finish  
Finition brillance/ Finitura lucida

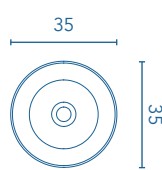

Profundidad del seno 12,5/ Sink depth 12,5/ Profondeur du bac 12,5/ Profondità della vasca 12,5

Acabado brillo/ Gloss finish  
Finition brillance/ Finitura lucida

**GALAXY**   
Ref. 116985 

**NOMIA**   
Ref. 125818 

**NYSA**   
Ref. 125816 

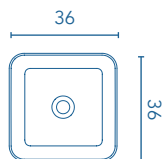

Profundidad del seno 12,5/ Sink depth 12,5/ Profondeur du bac 12,5/ Profondità della vasca 12,5

Acabado brillo/ Gloss finish  
Finition brillance/ Finitura lucida

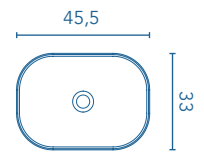

Profundidad del seno 13,5/ Sink depth 13,5/ Profondeur du bac 13,5/ Profondità della vasca 13,5

Acabado mate/ Matt finish  
Finition mat/ Finitura opaca

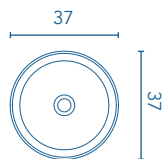

Profundidad del seno 12/ Sink depth 12/ Profondeur du bac 12/ Profondità della vasca 12

Acabado mate/ Matt finish  
Finition mat/ Finitura opaca

**ZALA**   
Ref. 125817 

**BLOCK**    
Ref. 126289 

**SUN**    
Ref. 126288 

## LAVABOS MINERAL COVER SOBRE ENCIMERA

Mineral cover countertop washbasins/ Plans vasques mineral cover à poser sur plan/ Lavabi mineral cover per tops

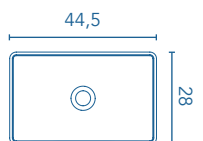

Profundidad del seno 12/ Sink depth 12/ Profondeur du bac 12/ Profondità della vasca 12

Acabado mate/ Matt finish  
Finition mat/ Finitura opaca

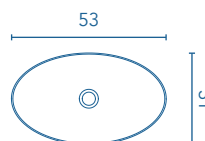

Profundidad del seno 11,5/ Sink depth 11,5/ Profondeur du bac 11,5/ Profondità della vasca 11,5

Acabado mate/ Matt finish  
Finition mat/ Finitura opaca

**TAOS**    
Ref. 126290 

**VOLTA**    
Ref. 126724 

ES\_Códigos sombreados en stock.  
EN\_Shaded codes are in stock.  
FR\_Les codes surlignés sont en stock.  
IT\_I codici ombreggiati sono in stock.

## ESPEJOS

Mirrors/ Miroirs/ Specchi



ES\_Dispone de hueco para el transformador.  
Perfil con acabado gris.

EN\_Features a recess for the transformer.  
Profile with brilliant chrome finish.

FR\_Dispose d'un espace pour le transformateur.  
Profil avec finition chromée brillante.

IT\_Dispone di spazio per il trasformatore.  
Profilo con finitura cromata lucida.

Profundidad/ Thickness/ Épaisseur/ Profondità: 2,6 cm.

### MURANO

**60 x 70** Ref. 122547

**70 x 70** Ref. 122548

**80 x 70** Ref. 122549

**90 x 70** Ref. 122550

**100 x 70** Ref. 122551

**120 x 70** Ref. 122552



ES\_Dispone de hueco para el transformador.  
Luna con cantos redondeados.

EN\_Features a recess for the transformer.  
Glass with rounded edges.

FR\_Dispose d'un espace pour le transformateur.  
Vitre avec angles arrondis.

IT\_Dispone di spazio per il trasformatore.  
Specchio con frontali smussati.

Cristal pulido/ Polished glass/ Miroir poli/ Vetro pulito.  
Profundidad/ Thickness/ Épaisseur/ Profondità: 2 cm.

### ESFERIC

**60 x 70** Ref. 117936

**80 x 70** Ref. 117040

**100 x 70** Ref. 117041

**120 x 70** Ref. 124799

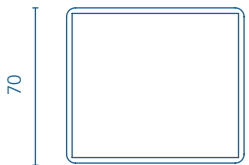

ES\_Dispone de hueco para el transformador.  
Luz blanca LED integrada.  
Luna de cantos redondeados.

EN\_Features a recess for the transformer.  
White LED light integrated into the mirror.  
Glass with rounded edges.

FR\_Dispose d'un espace pour le transformateur.  
Lumière blanche LED intégrée dans le miroir.  
Miroir aux bords arrondis.

IT\_Dispone di spazio per il trasformatore.  
Luce bianca LED integrata nello specchio.  
Specchio con bordatura addolcita.

Cristal pulido/ Polished glass/ Miroir carré poli/ Cristallo a bordo diamantato.  
220V - 240V · 1 x max. 15W.  
Profundidad/ Thickness/ Épaisseur/ Profondità: 2,1cm.

### STELLA

**60 x 70** Ref. 121850

**80 x 70** Ref. 121851

**100 x 70** Ref. 121852

**120 x 70** Ref. 121853

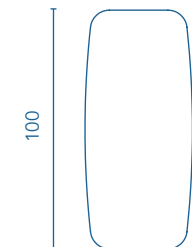

ES\_Dispone de hueco para el transformador.  
Trasera de madera con acabado gris.  
Luna rectangular con cantos redondeados y forma ovalada de 4 mm.

EN\_Features a recess for the transformer.  
Wooden rear with grey finishing.  
Rectangular 4 mm glass with rounded edges and an oval shape.

FR\_Dispose d'un espace pour le transformateur.  
Panneau arrière en bois finition grise.  
Miroir rectangulaire avec angles arrondis et forme ovale de 4 mm.

IT\_Dispone di spazio per il trasformatore.  
Parte posteriore in legno con rifinitura grigia.  
Specchio rettangolare con frontali smussati e dalla forma ovale di 4 mm.

Profundidad/ Thickness/ Épaisseur/ Profondità: 2 cm.

### LONGO

**45 x 100** Ref. 125526

**45 x 100** Ref. 125527

**Luna cobriza**  
Copper mirror  
Miroir cuivré  
Specchio di rame



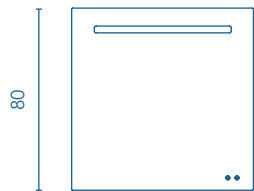

ES\_Conexión USB para cargar el teléfono. Luz neutra LED integrada en el espejo. Sistema antivaho. Interruptores táctiles ON/OFF para luz y antivaho. Perfil metálico con acabado cromado.

EN\_USB connection. Neutral LED light integrated into the mirror. Defogging system. Tactile ON/OFF switches for lights and defogging. Metallic profile with chrome finish.

FR\_Connexion USB. Lumière blanche LED intégrée dans le miroir. Système antibuée. Interrupteurs tactiles ON/OFF pour la lumière et le système antibuée. Profil métallique avec finition chromée.

IT\_Connessione USB. Luce neutra LED integrata nello specchio. Sistema antiappannante. Interruttori tattili ON/OFF per luce e antiappannante. Profilo metallico con rifinitura cromata.

Luna cuadrada pulida/ Square polished glass/ Miroir carré poli/ Specchio quadrato levigato. Temperatura/ Temperature/ Température/ Temperatura: 4000K.

Profundidad/ Thickness/ Épaisseur/ Profondità: 3 cm.

#### BOIRA

60 x 80

Ref. 125519

80 x 80

Ref. 125520

100 x 80

Ref. 125521

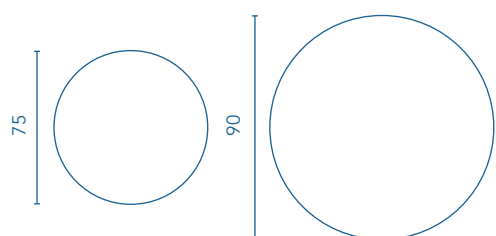

ES\_Trasera cuadrada de aglomerado en acabado gris.

EN\_Agglomerate rear in grey.

FR\_Panneau arrière en aggloméré finition grise.

IT\_Struttura in agglomerato finitura grigio.

Luna circular pulida de 4mm/ 4mm polished glass/ Miroir poli de 4mm/ Specchio filo lucido da 4 mm.

Profundidad/ Thickness/ Épaisseur/ Profondità: 2 cm.

NEW

#### YUE

Ø 75

Ref. 126691

Ø 90

Ref. 126692

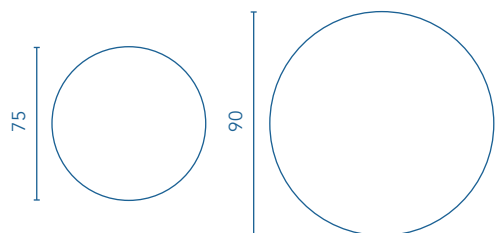

ES\_Luz neutra LED integrada en el espejo. Perfil metálico circular con acabado cromado.

EN\_Neutral LED light integrated into the mirror. Circular metallic profile with chrome finish.

FR\_Lumière blanche LED intégrée dans le miroir. Profil métallique circulaire avec finition chromée.

IT\_Luce neutra LED integrata nello specchio. Profilo metallico circolare con finitura cromata.

Luna pulida/ Polished glass/ Miroir poli/ Specchio levigato. Temperatura/ Temperature/ Température/ Temperatura: 4000K.

Profundidad/ Thickness/ Épaisseur/ Profondità: 2,5 cm.

#### LUA

Ø 75

Ref. 125522

Ø 90

Ref. 125523

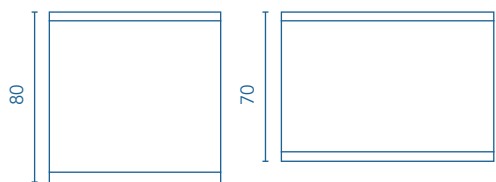

ES\_Luz neutra LED integrada en espejo. Espejo reversible, puede colocarse tanto en horizontal como en vertical. Perfil metálico con acabado cromado.

EN\_Neutral LED light integrated into the mirror. Reversible mirror, it can be positioned either horizontally or vertically. Metallic profile with chrome finish.

FR\_Lumière blanche LED intégrée dans le miroir. Miroir réversible, peut être posé aussi bien horizontalement que verticalement. Profil métallique avec finition chromée.

IT\_Luce neutra LED integrata nello specchio. Specchio reversibile, si può posizionare sia in orizzontale che in verticale. Profilo metallico con rifinitura cromata.

Temperatura/ Temperature/ Température/ Temperatura: 4000K.

Profundidad/ Thickness/ Épaisseur/ Profondità: 2 cm.

#### DUE

80 x 80 Rev.

Ref. 125524

100 x 70 Rev.

Ref. 125525



ES\_Códigos sombreados en stock.  
EN\_Shaded codes are in stock.  
FR\_Les codes surlignés sont en stock.  
IT\_I codici ombreggiati sono in stock.

## FENIX\_CAMERINO

**Mirror cabinet/ Armoire de toilette/ Specchio contenitore**

Camerino/ Mirror cabinet/ Armoire de toilette/ Specchio contenitore

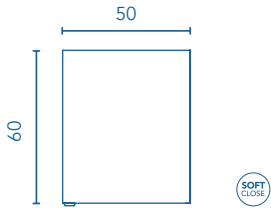

Profundidad/ Depth/ Profondeur/ Profondità: 13.

ES\_Costados exteriores y cantos en espejo. Interiores en mokka. Tirador metálico cromo brillo. Interior: 2 estantes de cristal.

EN\_Exterior struts and edged mirror. Interiors with mokka finish. Shiny chrome metal handle. Interior: 2 glass shelves.

FR\_Côtés extérieurs et bords miroir. Intérieur en finition mokka. Poignée en métal chromé brillant. Intérieur: 2 étagères en verre.

IT\_Fronte e laterali a specchio. Interni in finitura mokka. Maniglia metallica cromata lucida. Interno: 2 mensole di vetro.

Espejo/ Mirror/ Miroir/ Specchio

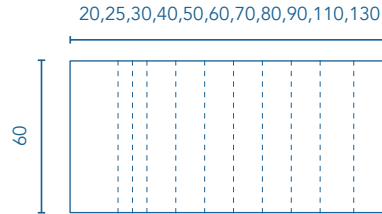

Profundidad/ Depth/ Épaisseur/ Profondità: 2.

ES\_Espejo con trasera, sin rebaje, de 1,6 y canto espejo.

EN\_Mirror with backing, without reduction, of 1.6 and edged mirror.

FR\_Miroir avec face arrière, sans décaissement, 1,6 et bord du miroir.

IT\_Specchio con retro, senza incavo, de 1,6 e bordo a specchio.

Repisa espejo/ Mirror shelf/ Étagère miroir/ Ripiano



Profundidad/ Depth/ Profondeur/ Profondità: 10,5.

ES\_Repisa en acabado gris aluminio satinado.

EN\_Shelf in grey satin aluminium finish.

FR\_Étagère en finition aluminium gris satiné.

IT\_Mensola in finitura grigio alluminio satinato.

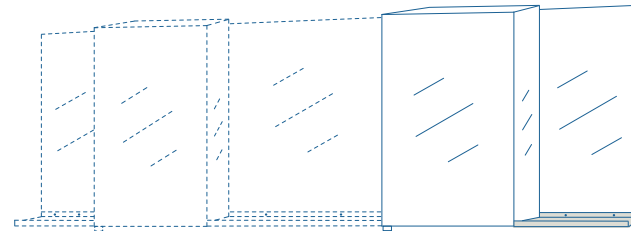

**NEW** FENIX

Camerino/  
Mirror cabinet/  
Armoire de toilette/  
Specchio contenitore

50 1P

Ref. 126704

**NEW** FENIX

Espejo/ Mirror/  
Miroir/ Specchio

20 x 60

Ref. 126705

25 x 60

Ref. 126706

30 x 60

Ref. 126707

40 x 60

Ref. 126708

50 x 60

Ref. 126709

60 x 60

Ref. 126710

70 x 60

Ref. 126711

80 x 60

Ref. 126712

90 x 60

Ref. 126713

110 x 60

Ref. 126714

130 x 60

Ref. 126715

**NEW** FENIX

Repisa espejo/ Mirror shelf/  
Étagère miroir/  
Ripiano

20

Ref. 126558

25

Ref. 126559

30

Ref. 126560

40

Ref. 126561

50

Ref. 126562

60

Ref. 126563

70

Ref. 126564

80

Ref. 126565

90

Ref. 126566

## NIKA\_CAMERINO

Mirror cabinet/ Armoire de toilette/ Specchio contenitore

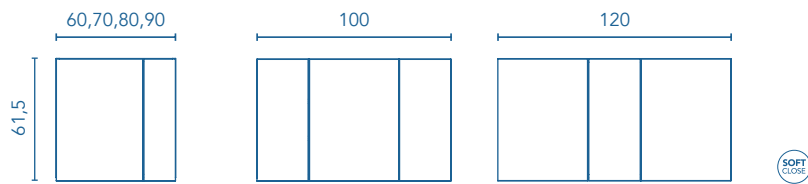

Profundidad/ Depth/ Profondeur/ Profondità: 13,5.

ES\_Costados exteriores en melamina gris metálica o lacados en blanco. Interior: 2 estantes de cristal.

EN\_Profile is available in two finishes, lacquered white and metallic grey melamine. Interior: 2 glass shelves.

FR\_Côtés extérieurs disponible en deux finitions, laquée blanche et mélamine grise métallique. Intérieur: 2 étagères en verre.

IT\_Struttura disponibile in due finiture, laccata bianca e melamina grigia metallica. Interno: 2 mensole di vetro.

NIKA



60

Ref. 119113

Ref. 119865

70

Ref. 119114

Ref. 119754

80

Ref. 119115

Ref. 120094

90

Ref. 119116

Ref. 119755

100

Ref. 119117

Ref. 120316

120

Ref. 119118

Ref. 119756

ES\_Códigos sombreados en stock.  
EN\_Shaded codes are in stock.  
FR\_Les codes surlignés sont en stock.  
IT\_I codici ombreggiati sono in stock.

Royo Modular.

## LUMINARIAS LED

LED wall lights/ Luminaires LED/ Illuminazione LED



220V - 240V ~ 50Hz.

1 x max. 8W (Llum 30).  
1 x max. 12W (Llum 50).

1 Luminaria/ caja.  
1 Luminary/ box.  
1 Luminaire/ boîte.  
1 Illuminazione/ scatola.

**LLUM 30**

Ref. 124752

**LLUM 50**

Ref. 124753



220V - 240V ~ 50Hz.

1 x max. 8W (Luce 30).  
1 x max. 12W (Luce 50).

1 Luminaria/ caja.  
1 Luminary/ box.  
1 Luminaire/ boîte.  
1 Illuminazione/ scatola.

**LUCCE BLACK 30**

Ref. 125158

**LUCCE 30**

Ref. 123395

**LUCCE 50**

Ref. 123396

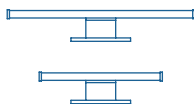

Temperatura/ Temperature/ Température/  
Temperatura: 4000K.

3W / 300 LM (Uri 20).  
4W / 400 LM (Uri 30).

1 Luminaria/ caja.  
1 Luminary/ box.  
1 Luminaire/ boîte.  
1 Illuminazione/ scatola.

**URI 20**

Ref. 126073

**URI 30**

Ref. 126266



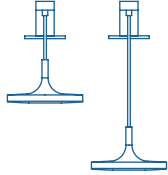

Temperatura/ Temperature/ Température/  
Temperatura: 4000K.

5W / 400 LM.

1 Luminaria/ caja.  
1 Luminary/ box.  
1 Luminaire/ boîte.  
1 Illuminazione/ scatola.

**SUNNA 15**

Ref. 126339

**SUNNA 25**

Ref. 126217

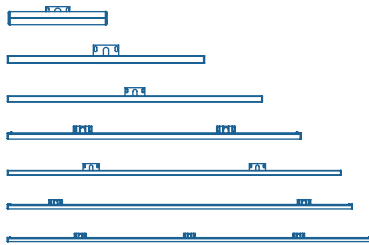

230 V ~ 50 Hz.

1 x max. 3W (Alea 16).  
1 x max. 6W (Alea 30, 60).  
1 x max. 10W (Alea 50).  
1 x max. 15W (Alea 80).  
1 x max. 12W (Alea 100, 120).

1 Luminaria/ caja.  
1 Luminary/ box.  
1 Luminaire/ boîte.  
1 Illuminazione/ scatola.

**ALEA 16**

Ref. 123062

**ALEA 30**

Ref. 124862

**ALEA 50**

Ref. 124863

**ALEA 60**

Ref. 123028

**ALEA 80**

Ref. 124864

**ALEA 100**

Ref. 122868

**ALEA 120**

Ref. 123029



ES\_Códigos sombreados en stock.  
EN\_Shaded codes are in stock.  
FR\_Les codes surlignés sont en stock.  
IT\_I codici ombreggiati sono in stock.

## ACCESORIOS SUMI NEW

Sumi accessories/ Accessoires Sumi/ Accessori Sumi

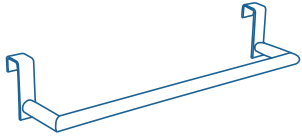

ES\_Accesorio sin taladro, no necesita elementos de fijación. Material: latón. Soporta hasta 5kg de peso.

EN\_Accessory without drilling, no fixing elements needed. Material: brass. It supports up to 5kg of weight.

FR\_Accessoire sans percement, pas besoin de fixation. Matériaux: laiton. Supporte maximum 5 kg de charge.

IT\_Accesorio che non richiede l'utilizzo del trapano e non necessita elementi di fissaggio. Materiale: ottone. Soppoporta fino a 5 kg di peso.

Tubo/ Tube/ Tube/ Tubo: Ø16 mm.

**TOALLERO**  
Towel holder/  
Support porte-  
serviette/  
Portasciugamano

27,5

37,5

Ref. 126164	Ref. 126161	
Ref. 126165	Ref. 126162	
Ref. 126163	Ref. 126160	

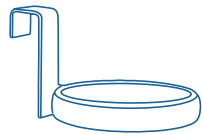

ES\_Accesorio sin taladro, no necesita elementos de fijación. Material: latón. Soporta hasta 5kg de peso.

EN\_Accessory without drilling, no fixing elements needed. Material: brass. It supports up to 5kg of weight.

FR\_Accessoire sans percement, pas besoin de fixation. Matériaux: laiton. Supporte maximum 5 kg de charge.

IT\_Accesorio che non richiede l'utilizzo del trapano e non necessita elementi di fissaggio. Materiale: ottone. Soppoporta fino a 5 kg di peso.

**SOPORTE  
SECADOR  
DE PELO**

Ø 93,5

Hair dryer holder/  
Support sèche-  
cheveux/ Supporto  
per asciugacapelli

Ref. 126167	
Ref. 126168	
Ref. 126166	

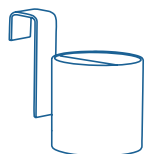

ES\_Accesorio sin taladro, no necesita elementos de fijación. Material: latón. Soporta hasta 5kg de peso.

EN\_Accessory without drilling, no fixing elements needed. Material: brass. It supports up to 5kg of weight.

FR\_Accessoire sans percement, pas besoin de fixation. Matériaux: laiton. Supporte maximum 5 kg de charge.

IT\_Accesorio che non richiede l'utilizzo del trapano e non necessita elementi di fissaggio. Materiale: ottone. Soppoporta fino a 5 kg di peso.

**SOPORTE  
PLANCHA  
DE PELO**

Ø 60

Hair stylin iron holder/  
Support fer à lisser/  
Supporto per piastra  
per capelli

Ref. 126170	
Ref. 126171	
Ref. 126169	

## VÁLVULA CLIC-CLAC <sup>NEW</sup>

Click-clack valve/ Vidage clic-clac/ Valvola click-clack

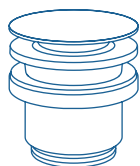

Ref. 126818



Blanco mate/ Matt white  
Blanc mat/ Bianco opaco

Ref. 126819



Arena mate/ Sand matt finish  
Sable mat/ Sabbia matte

Ref. 121398



Cromo/ Chromée/  
Chrome/ Cromo

## ESCUADRA

Bracket/ Équerre/ Staffe

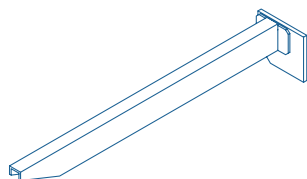

1 unidad/ 1 unit/ 1 unité/ 1 unità.

40 x 1,7 x 3,5

Ref. 126899



ES\_Escuadra para consola con lavabo integrado Sky. Para medidas de hasta 120: 2 escuadras; de 140 a 180: 3 escuadras; para 200: 4 escuadras.

EN\_Bracket for Sky console with built-in washbasin. For sizes up to 120: 2 brackets; from 140 to 180: 3 brackets; for 200: 4 brackets.

FR\_Équerre pour console vasques intégrées Sky. Pour dimensions allant jusqu'à 120: 2 équerres; de 140 à 180: 3 équerres; pour 200: 4 équerres.

IT\_Staffe per console con lavabo integrato Sky. Per misure fino a 120: 2 staffe; da 140 a 180: 3 staffe; per 200: 4 staffe.

ES\_Códigos sombreados en stock.  
EN\_Shaded codes are in stock.  
FR\_Les codes surlignés sont en stock.  
IT\_I codici ombreggiati sono in stock.

ACABADOS  
*FINISHES*  
*FINITIONS*  
*FINITURE*

---





## MELAMINA

Melamine/ Mélamine/ Melamina

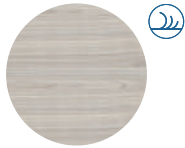

GR21: GRIS ARENADO/  
SANDY GREY/ GRIS SABLÉ/  
GRIGIO SABBATO



NO14: NOGAL ARENADO/ SANDY  
WALNUT/ COLORIS NOYER SABLÉ/  
NOCE SABBATO



## RECUBRIMIENTO 2D

Wrapping foil in 2D/ Revêtement 2D/ Rivestimento 2D

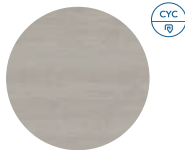

RO8: ROBLE BLANCO/  
WHITE OAK/ COLORIS  
CHÊNE BLANC/  
ROVERE BIANCO



OL1: OLMO GRIS/  
GREY ELM/ ORME  
GRIS/ OLMO GRIGIO

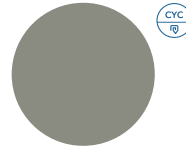

MA15M: ARENA MATE/  
SAND MATT FINISH/ SABLE  
MAT/ SABBIA MATTE

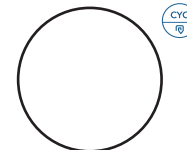

BL20M: BLANCO MATE/  
MATT WHITE/ BLANC  
MAT/ BIANCO OPACO



## RECUBRIMIENTO 3D

Wrapping foil in 3D/ Revêtement 3D/ Rivestimento 3D



BL19: BLANCO NATURE/  
NATURE WHITE/ BLANC  
NATURE/ BIANCO NATURE



RO6: BEIGE NATURE/  
NATURE BEIGE/ BEIGE  
NATURE/ BEIGE NATURE



MA15M: ARENA MATE/  
SAND MATT FINISH/ SABLE  
MAT/ SABBIA MATTE

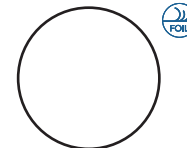

BL20M: BLANCO MATE/  
MATT WHITE/ BLANC  
MAT/ BIANCO OPACO



## LACADOS ALTO BRILLO

High gloss lacquered/ Laqué haute brillance/ Laccato super brillante

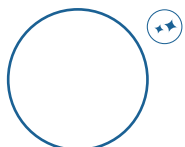

BL1B: BLANCO/ WHITE/  
BLANC/ BIANCO



GR16B: ANTRACITA/ ANTHRACITE/  
ANTHRACITE/ ANTRACITE

## ROYO

---

Street Río Vinalopó 69 (A-3, Km 344,4)  
46930 - Quart de Poblet - Valencia - Spain  
[info@royogroup.com](mailto:info@royogroup.com)

[www.royogroup.com](http://www.royogroup.com)  
tel (+34) 96 389 73 73  
fax (+34) 96 192 01 12

---

Art Direction, Design and Layout  
Odosdesign  
[www.odosdesign.com](http://www.odosdesign.com)

---



